

EMOST®

The new medical therapy



EMOST Redox 1.1 MEDICAL DEVICE



PRESENTATION FORM

Name of Product: EMOST™ Own Signal Therapy

1. What is the profile of the company?

- developing and manufacturing the EMOST™ medical device
- service of this medical device only, and sales of this device only

2. How long has the firm been in operation?

For 7 years

3. What are the advantages of the current method?

- alternative procedure to neurological based diseases
- chemical agent-free, convenient
- may be provided as a course (4-5 treatments, repeated annually)
- effects on hormones and regulators

4. How does this resolve a particular sector's problem?

- safe method of sensitive intervention in the case of nervous system based diseases
- does not cause personality disorder
- no side effects* (extremely low risks only)
- may be a simpler and a more effective therapy than the use of chemical agents and psychotherapy

5. How would it reflect the volume of sector?

panic attacks (2.5%), anxiety (8.5%), depression (2.6%), sleeping disorders (6.7%), stroke-risk (6.9%), cardiological risk (11.7%), arrhythmia (4,1%), digestive diseases (8.9%), allergy (4.2%). *Source: WHO Epidemiology EU- 2010*

6. What is the main benefit and other benefits?

- the main benefit: easy-to-use
- cost-effective way
- relatively long-term results
- low number of treatments needed
- no addiction, no defensive reactions in healing

7. How much capital is needed for the investment?

The device: 29,900 EUR + VAT

8. What is the order of capital requirements?

50% at the time of the order, 50% at delivery

9. What is the payback period?

The device: 83 patients (360 EUR/cure/patient), 6-8 months
Marketing: 60% 50 patients
Wage cost: 60% 50 patients

10. What is the period for completion?

Delivery: 60 days, teaching, training: 60 hours

11. What financing options are added?

50% upon ordering, 50% at delivery, ability to leasing, promotion of job-creation in the EU, option of state-supported financial assistance in medical sector.

12. Name of a reference, and a photo:

Dr. Veronika Hajda (+36 30 999 99 47)



Chairman: Dr. Attila Erdőfi-Szabó Ph.D.
Phone: +36 30 940 5989, www.emost-med.com



Potential

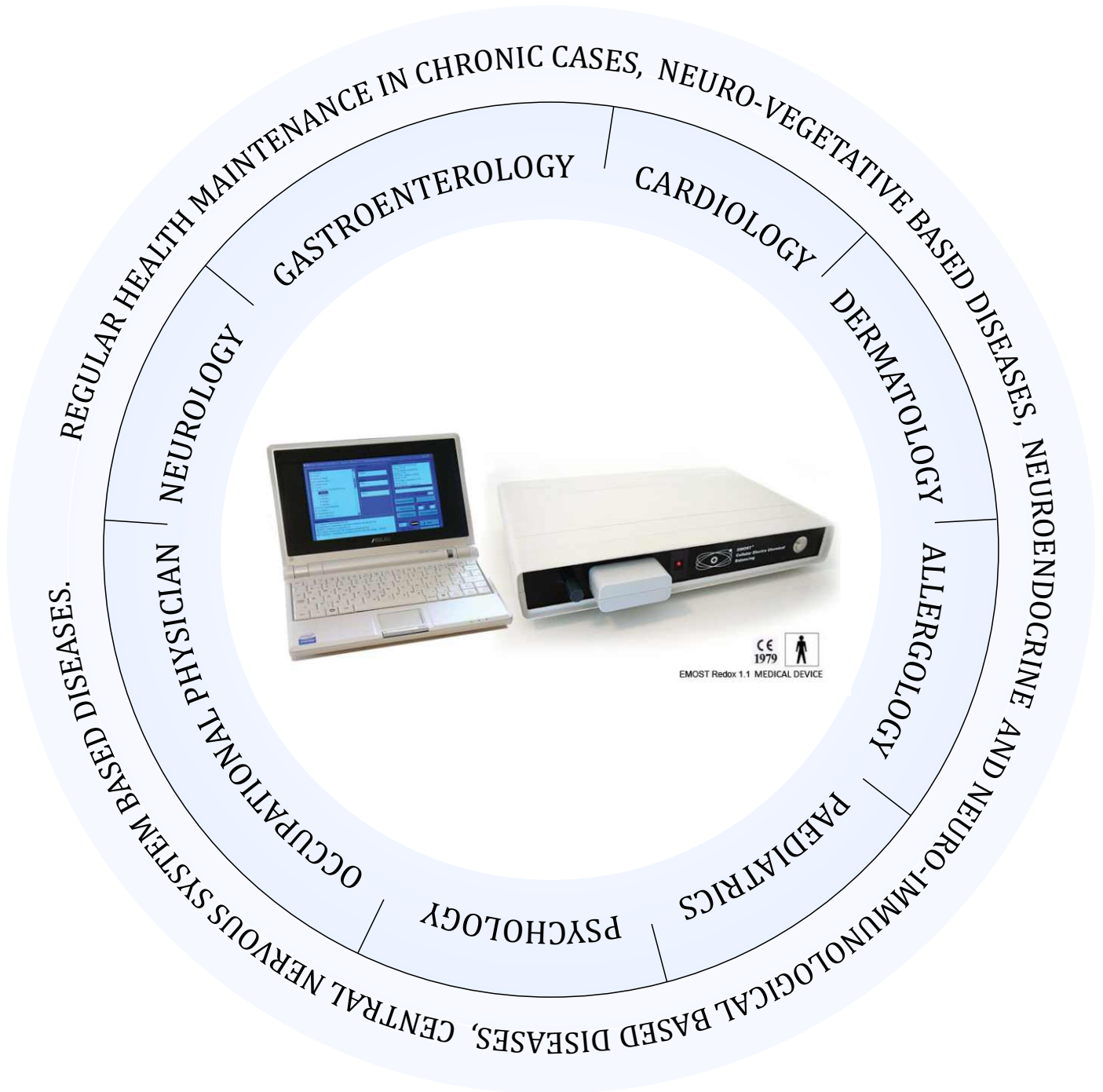

Keywords: psychological and nervous system background





Potential in SPA



Keywords: biological upgrade



INFORMATION AS SOON AS - biosensors Own Signals

Upgrade your health, records in spontaneous healing



The main aim of the Humans is to perform the process of self-recovery, meaning that your body is able to heal itself. I think we got very close to it. After more than a decade of research we can say that humans are able to recover control of their own state, similarly, when we are tired from working hard and go to bed at night and we wake up fresh in the morning. How does it happens? We deal with this process.

The Company:

Our company, BioLabor Biophysical and Laboratory Service Ltd. has got several years' professional experience and also a kind of conservative approach to life. We have gathered skilled colleagues to organize a team in which people can not only look after the patients but are sufficiently open to cutting-edge technologies as well. Our staff and company proprietors work in different areas of healthcare and are outstanding representatives of general practitioners, internists, surgeons, military doctors, natural therapeutics, pharmacists, haematologists, university teachers, scientists, and every colleague has been using our own-produced technology with success in their daily routine for years. The Company attends many national and international congresses and conferences every year. Recently we took part in the 8th European Biophysics Congress and International Conference of Preventive Medicine and Public Health, International Conference of Preventive Medicine and Public Health at Pécs, Hungary, National Family Doctors Congress Romania, and Neurology Congress at Ukrainian National Science Academy.

The Company's function:

- a) Scientific work, education, development of EMOST medical therapy
- b) Service of EMOST therapy countryside, and sale of BioLabor franchise in Europe
- c) Manufacturing of BioLabor EMOST Redox medical devices
- d) Clinical laboratory: serology, mycology, virology, bacteriology, screening tests
- e) Factory medical services
- f) 7/7 Customer service, operation (close to 70 BioLabor Health Center in Europe)

Indications of procedure:

Regular health maintenance in chronic cases, neuro-vegetative based diseases, neuroendocrine and neuro-immunological based diseases, central nervous system based diseases.

We could effectively treat diseases such as:

fear, panic attacks, inhibition, psychic stress related (mental) diseases, epilepsy, depression, lethargy, sleep disorders, cardiovascular diseases, arrhythmia, asthma bronchial, chronic shortness of breath, phantom limb pain and amputee rehabilitation, rehabilitation of Post-Traumatic Stress Diseases, allowance of risks in implantation, chronic stomach cramps, irritable intestine syndrome, cognitive difficulties, bulimia, chronic constipation, incontinency, conception difficulties.

... upgrade your health and take a chance for better Life – EMOST medical therapy

We have partnerships with the followings:

National Institute for Medical Rehabilitation, Hungarian Army Independent Health Insurance, Independent Armed Forces Trades Union Congress, Hungarian Independent Police Union, National Police and Armed Forces Training Centre, Hungarian Civil Servants Union, Union of Hungarian HR's, National Athletic Association, Golden Hearth Foundation, some national and private clinics and rehabilitations centres, International Tisza Cluster Association (ITCA), Ukrainian Transcarpatian Develop Office (Zakarpattia), some discreet contract with politics and staff training centres, and HQ of International Bodyguard and Security Services Association (IBSSA), we have almost 100 franchise partners in Hungary, and representative medical clinics with earlier version of device in USA, Canada, Spain, Slovakia, Italy, Germany, United Kingdom, Poland, Romania, Ukraine, Columbia, Portugal, Angola.

The new medical procedure, Electro Magnetic Own Signal Therapy™

In our procedure the body heals by itself. We are able to connect the body's regulators in such a way, that allows the system to regenerate itself by using its own resources.



The method utilizes a connection of bidirectional communication between skin cells and the nervous system, because the skin is sophisticated sensory organ, mediates infinite numbers of stimulus. The equipment uses signals via free nerve endings of skin, uses the autonomous and central nervous

system's signal ways. It works continuously interactive contact by the body under treatment (EMOST™ know-how), over 40-60 minutes, it can parallel and continually refine the body's self-controlling and self-regulation processes.

The Electro-Magnetic Own Signal Therapy (EMOST) indicates the systematic diversion (extra-sense detection) and thematic recirculation (EMOST™ know-how) of extremely low intensity, electric- and electromagnetic signals (similarly to ECG and EEG signals, may potentials) of subjects skin, which belong to the person's various biological processes.

The device detects the internal signals of body in different signal density (1-1,000,000 signal/sec), some signals selecting (EMOST™ know-how) and makes variations of this signals (EMOST™ know-how), the original and variations transmittings back on skin (EMOST™ know-how), than the skin sensors detects internal signals out of external surface. The nervous system controlling those immediately as information and coherency natural based energy, than utilizes them according to healing and energy benefit.

Benefits of procedure:

The Own Signal Therapy helps to adjust and regulate directly the basic physiological flows, bio electrochemical synchronisation, event-event communications, potentials- action potentials changing, helps efficiency of organs and cells, in signal transmission and signal recognising (hormones), by doing that it helps the homeostasis to recover itself, and helps to recover in problematic cases.

Furthermore, the EM-Own Signal Therapy is non-invasive, no chemical input, its principle is the body's non-defence mechanism, doesn't use any artificial electric- and electromagnetic signals under sessions, this natural based signal can guarantee extreme low risks, because it works under the natural range of the body. It also improves efficiency by better coherence.

... upgrade your health and take a chance for better Life – EMOST medical therapy

Technical properties:

natural biofeedback, electrophysiological, extremely low intensity (its functional range is <10mikroTesla, <mV), natural based non-linear shaped signals, based on analogous signal processing, cyclical-dynamic impulse emission during interactivity, automated, well-indicated, requires 7,2 V DC, medical device certified **CE 1979**, directive 93/42/EEC, this procedure may unique of the World in functional sophistication and quality.

Basic information:

The device is high-tech and easy-to use, exclusive education for using not needed but helps the biological basics of mechanism in the technical understanding, this needs 20 hours. Long of treatment 45 minutes, the optimal numbers of patients per day would be six, and optimal periods in cure once a week, which would mean 30 people per week, price/treatment is 80 EUR, 95 USD, 10,000 HUF, price/cure is cca. 400 EUR/disease, recommended repeat 1-2 years.

Factors influencing the efficiency of the treatments:

Abnormal dehydration of the body, low fluid intake, nutrient deficiency, constant abnormal stress, constant unhealthy environment, constant unhealthy lifestyle.

Contra-indications:

Unclear state, acute vomiting, ventral pain, rapid pulse, vertigo, catatonic state, fainting, inability to communicate, personal sensitivity to the specific process, unexplained shivers.

Side effects

In biofeedback processes are extreme low risks.

Codes of competence of health professions (6/2012.(II.14) NEMFI HU, EU):

5704 physiotherapy, 5722 electro-physiotherapy, 6400 general medical care, 0100 general internal medical care, 0903 rehabilitation of neurology, 0500 general paediatrics, 9400 preventive- and public health care, 8046 reflexzone therapy, 8717 complementer electrophysiological care.

Advantage:

Several years of operational routine, medical device, high-tech and easy-to use, natural based healing procedure, the device: personal production, selling directly, favourable price in treatments and in device investment, this is a currently unique medical method at some problematic illnesses.

More informations: publications, documents etc. look at: www.biolabor-med.com

Look forward to seeing, best regards,

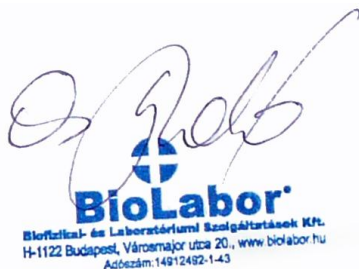

Dr. Attila Erdőfi-Szabó Ph.D., (pronunciation: Attila RDFE-XABO)
Phone: +36 30 940 5989, boss@biolabor.hu, Skype: dr.erdoft, Viber member
Chairman of EMOST Nano-MED Medical Device Manufacturer Ltd.
Chairman of BioLabor Biophysical and Laboratory Services Ltd.
Know-how owner, developer, head of engineering of Caduceum Ltd.

Competence of commerce: local Distributor

... upgrade your health and take a chance for better Life – EMOST medical therapy

Comparison to the best of our knowledge	EMOST™	Tens stimuli	Accupuncture	Electr-accupuncture	Homeopathy	Medicinal product	Psychiatry
self-medication	yes	no	no	no	no	no	maybe
self-regulating process	yes	no	no	no	yes	no	yes
natural healing	yes	no	no	no	maybe	no	yes
works via neurovegetative system	yes	yes	yes	yes	no	maybe	maybe
works in non-defense reactions	yes	no	maybe	maybe	no	maybe	yes
non-invasive	yes	no	no	no	no	no	maybe
use in course enough	yes	maybe	maybe	maybe	maybe	no	maybe
effect self-memorising	maybe	no	no	no	maybe	no	yes
natural based	yes	no	no	no	maybe	maybe	yes
use own biological signals	yes	no	no	no	maybe	no	yes
without contraindications	yes	no	no	no	maybe	no	yes
extrem-low risks	yes	no	yes	no	yes	maybe	yes
interactivity in median effective dose	yes	no	yes	no	no	no	yes
holds natural balance	yes	no	maybe	maybe	yes	maybe	yes
well-indicated	yes	maybe	yes	yes	yes	yes	no
activate the self-checking system	yes	yes	yes	maybe	yes	maybe	no
balance the electro-chemical processes	yes	maybe	yes	yes	yes	yes	maybe
balance the cellular metabolism	yes	yes	maybe	maybe	maybe	yes	maybe
balance the cellular electro-chemical flows	yes	maybe	yes	yes	no	maybe	no
balance parasymphatic and sympathic's	yes	no	yes	maybe	maybe	maybe	maybe
helps for the neurovegetative system	yes	yes	yes	yes	no	yes	maybe
helps in signal transmission	yes	no	yes	maybe	no	maybe	no
helps in signal recognising	yes	no	yes	maybe	no	maybe	no
helps via neurotransmitters	yes	maybe	maybe	maybe	maybe	yes	maybe
helps in flow of potential-action potential	yes	no	yes	no	no	no	no
helps in neuroendocrine balance	yes	no	no	no	maybe	maybe	yes
helps in neuro-immunological flows	yes	no	maybe	maybe	no	maybe	maybe
helps in psycho-somatic based problems	yes	no	no	no	maybe	maybe	yes
helps in somato-psychic based problems	yes	yes	yes	yes	yes	yes	yes
easy-to-use	yes	maybe	no	no	no	no	no

Results rates of EMOST treatments from developing period to medical certificate in BioLabor franchise system. (stats in CRM/14,921 courses/05-12, Dr. Attila Erdőfi-Szabó, chairman)

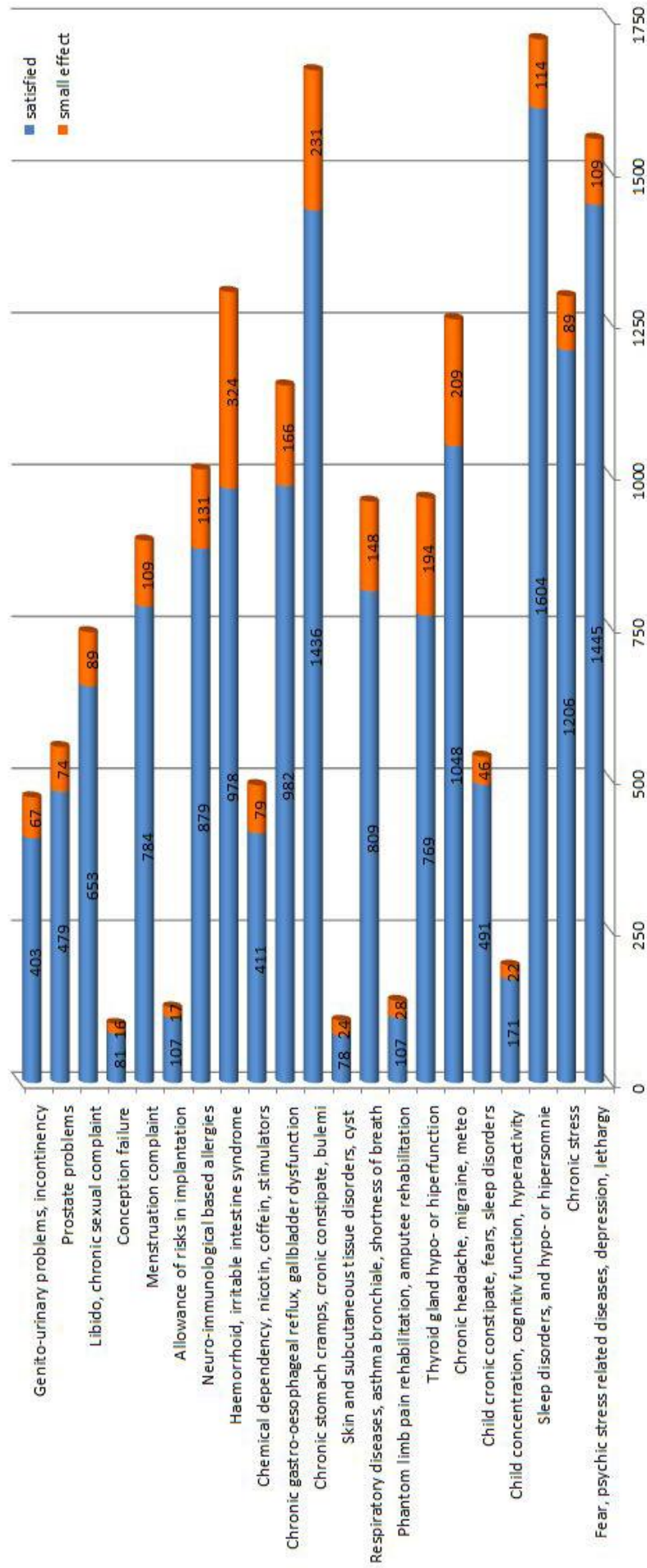

PROFESSIONAL INFORMATION

Life



Life

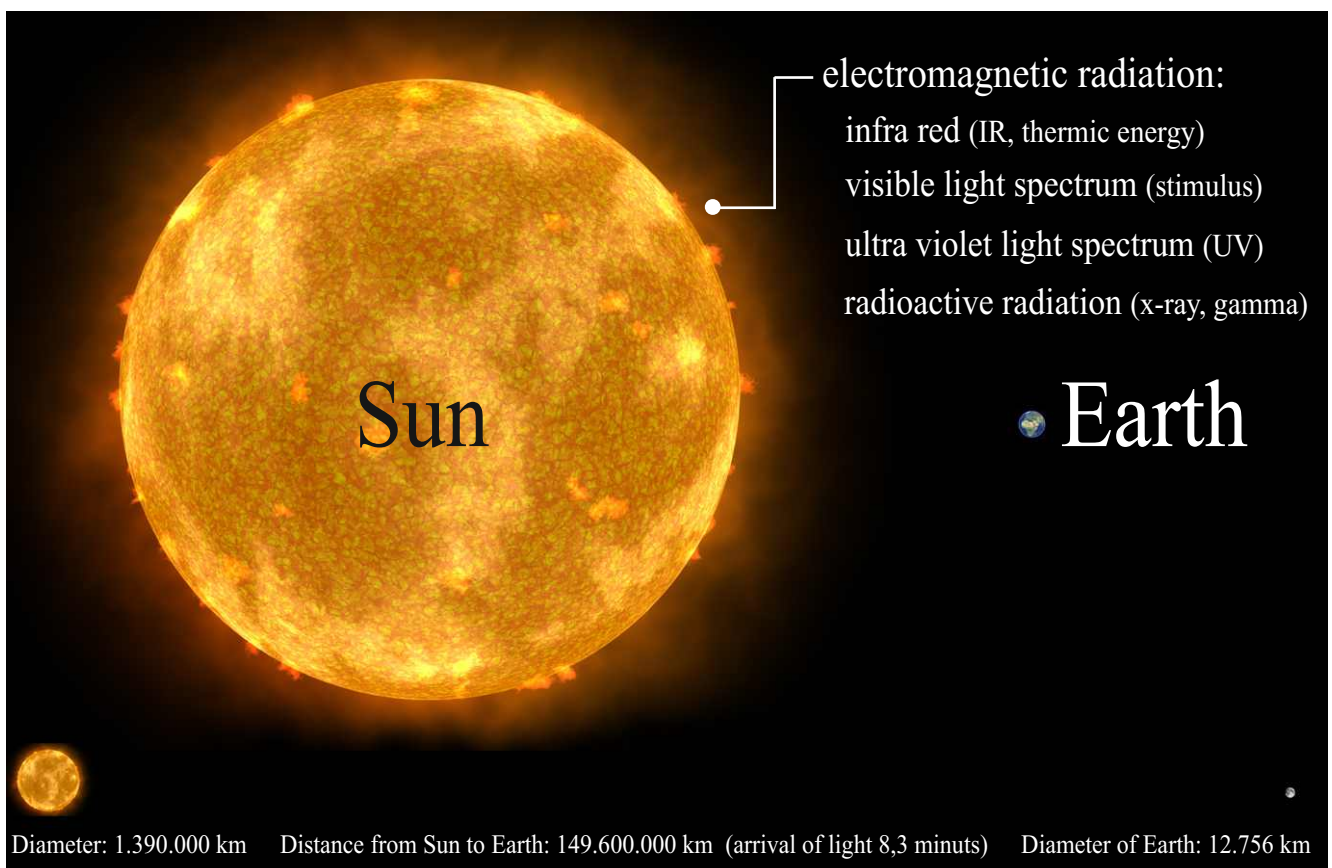

Life

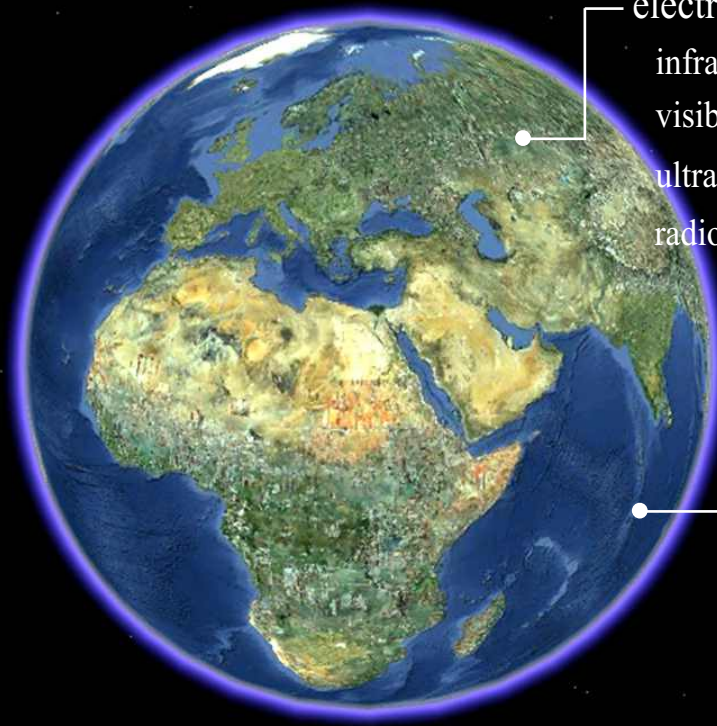

electromagnetic radiation:
infra red (IR, thermic energy)
visible light spectrum (stimulus)
ultra violet light spectrum (UV)
radioactive radiation (x-ray, gamma)

gravitation
atmosphere
heat
water
molecular properties

Life

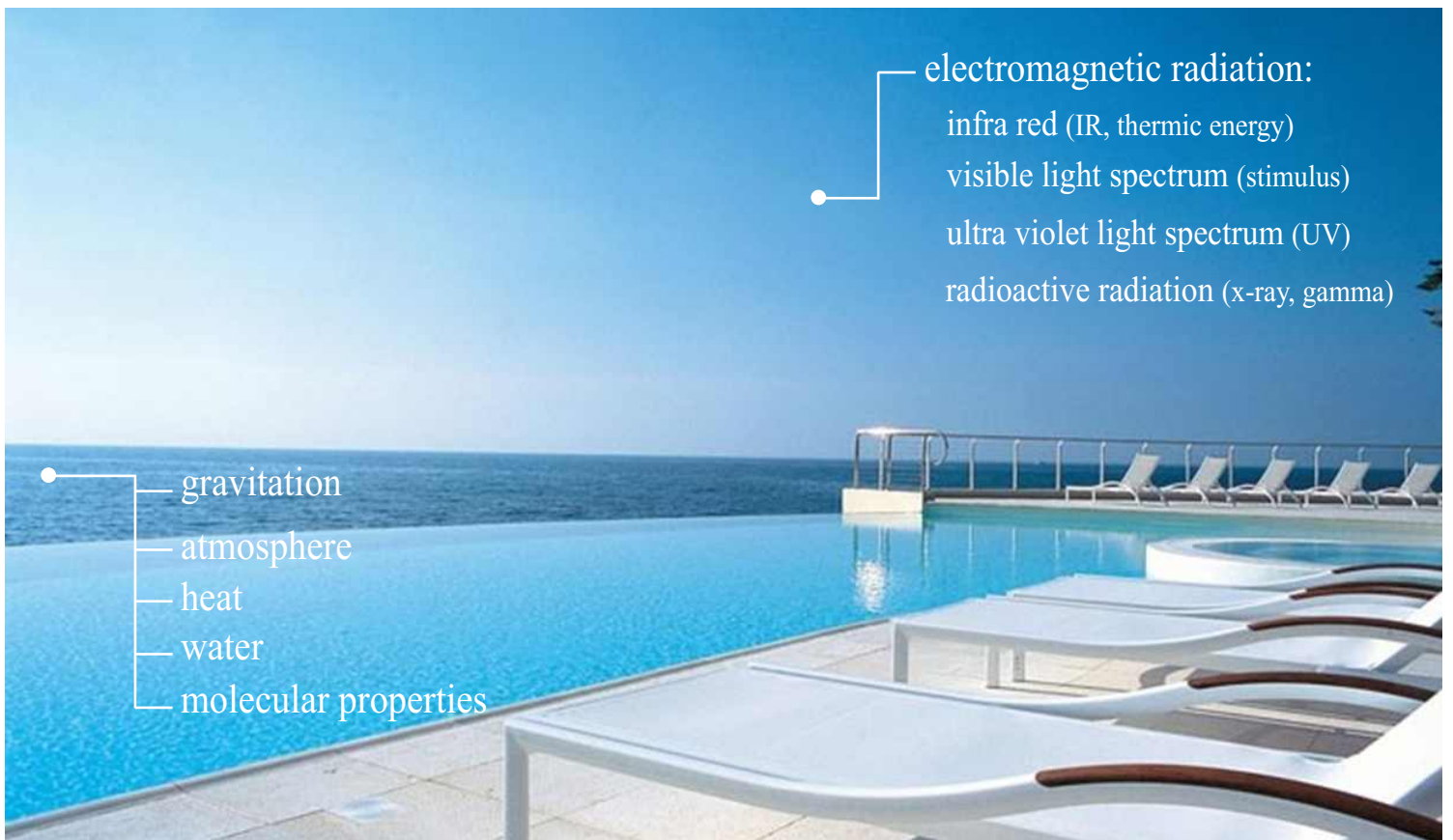

electromagnetic radiation:

infra red (IR, thermic energy)

visible light spectrum (stimulus)

ultra violet light spectrum (UV)

radioactive radiation (x-ray, gamma)

gravitation

atmosphere

heat

water

molecular properties

Life

electromagnetic radiation:

infra red (IR, thermic energy)

visible light spectrum (stimulus)

ultra violet light spectrum (UV)

radioactive radiation (x-ray, gamma)



retina (and skin)

transformation from electromagnetic
energies to stimuluses

Regulation

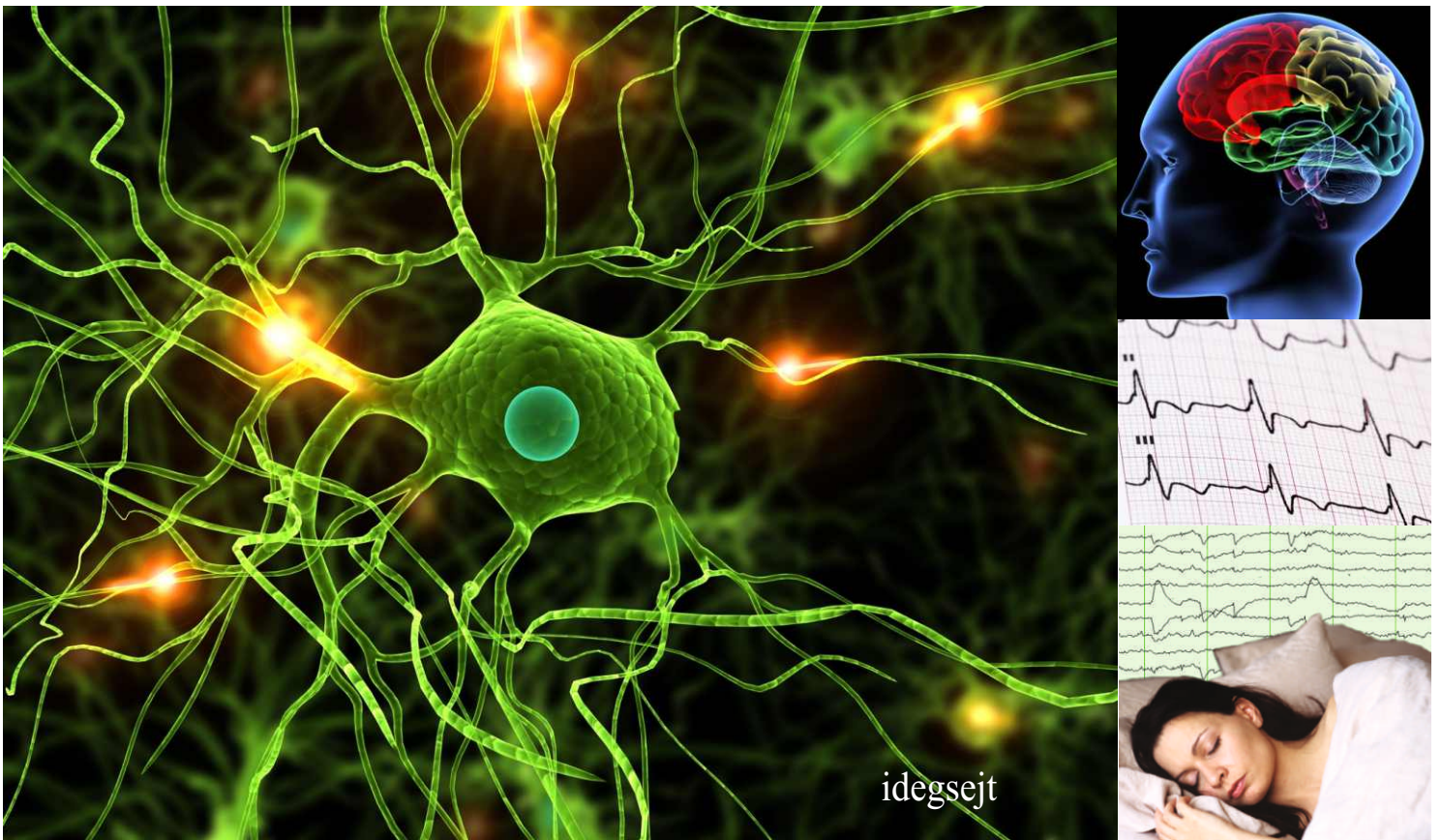

Life



Relationships

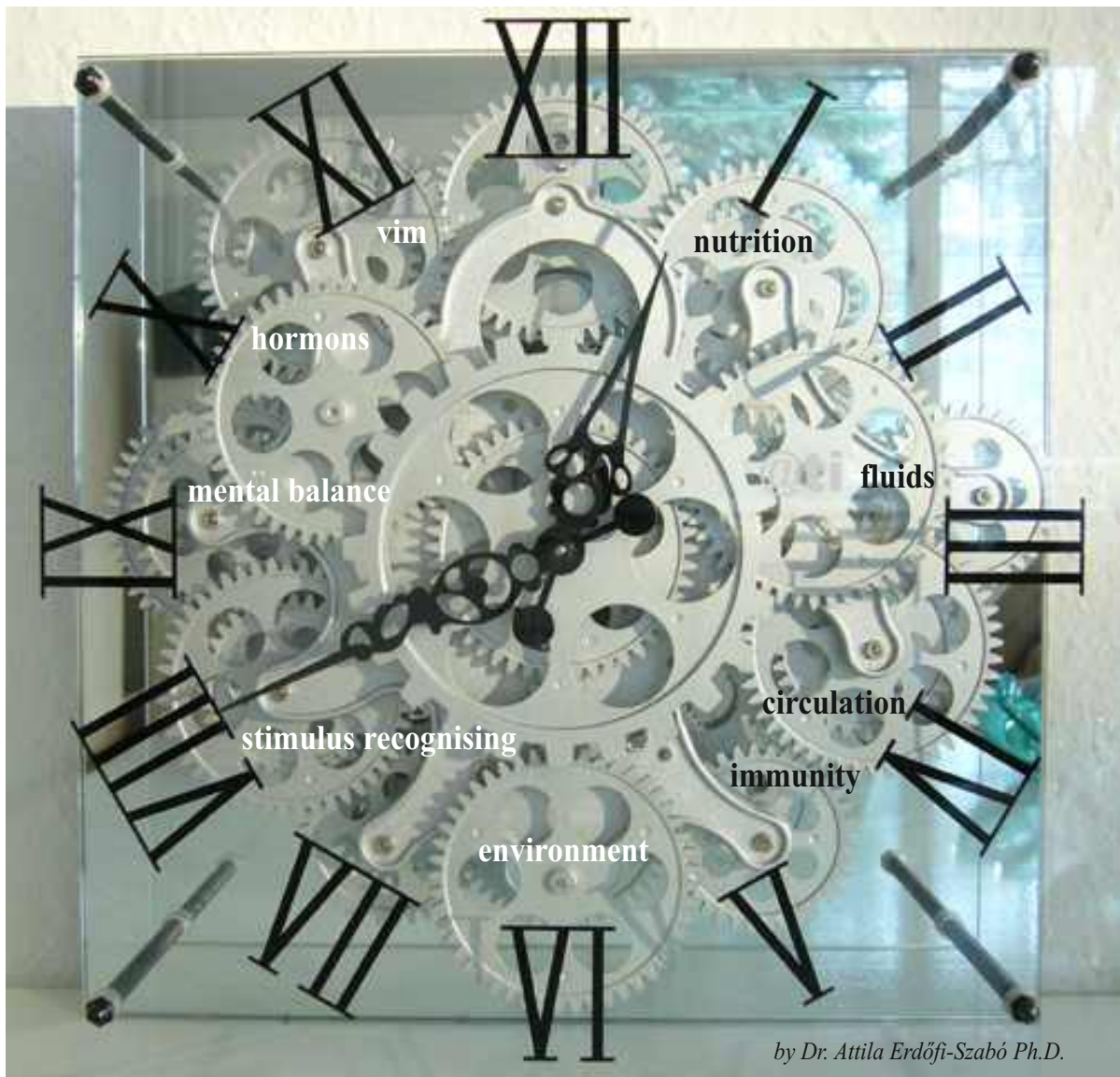

by Dr. Attila Erdőfi-Szabó Ph.D.

Balance



Self-recovering?



In our procedure
the body heals by itself.
We are able to connect
the body's regulators
in such a way,
that allows the system
to regenerate itself
by using its own resources.



Luxus



Is the self-recovering a Luxus?



The self-recovering is Your Luxus.



The EMOST therapy is the unique, natural based ElectroMagnetic Own Signal Therapy.

The EMOST Own Signal Treatment is a latest medical procedure in self-recovering.

Success



EMOST Redox 1.1 MEDICAL DEVICE

Take a chance for better Life!

Success



Success



Success



Success



Success



This is my world already!

Success

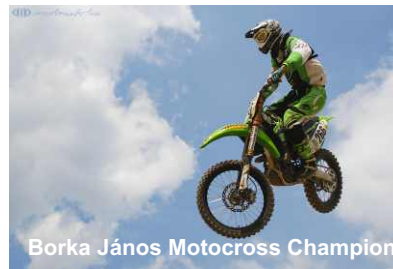

Success



EMOST

self-recovering method

Global potency

- searching self-recovering
- natural healing
- free from side effects
- long-term effect



The way is free...

Save Global Growth

- self-supporting HQ via services
- several years of operational routine
- personal production
- selling directly
- currently unique medical method

“The decade of bioinformatics follows the decade of informatics!” Bill Gates



The way is free...

E.M.O.S.T.
THE
ELECTRO-MAGNETIC OWN SIGNAL THERAPY



CE
1979
EMOST Redox 1.1 MEDICAL DEVICE

presented by

Dr. Attila Erdőfi-Szabó Ph.D.

Biophysicist, developer of EMOST method

doctor of Medical- and Health Sciences

www.biolabor-med.com

2011/2012

ELECTROMAGNETIC OWN SIGNAL TREATMENT

2012

TABLE OF CONTENTS

PROLOGUE	3
Supplement: Definitions	5
Bio-electrochemical knowledge	7
A short introduction about EMOST	18
Presumable effects of the EMOST	21
How output signals from EMOST device can reach to all parts of body.....	22
The EMOST process.....	25
How many treatments can be necessary by EMOST in a given disease.	26
BioLabor EMOST [®] effectiveness according to our last years experiences	27
The EMOST units	32
EMOST treatment flow	33
Elements of EMOST Device	34
Building the extrasense EMOST electrodes	35
EMOST Electrodes on skin	36
Power of Device, the accumulators	37
The BioLabor EMOST Software	38
Treatment data transmitting to Device	39
Testing the Device	41
Device properties	42
Datas	43
Relevant publications in print.....	44-279
Relevant publications via electronic version on CD-Rom	280-2371

ELECTROMAGNETIC OWN SIGNAL TREATMENT

2012

PROLOGUE

 The body refreshes itself every day: you go to bed tired in the evening, and then you get up in the morning "recovered", IE even from the most exhausted state you get much better by "something" while energy was not taken. How does it happens? We deal with this neuro-vegetative process.

Dr. Attila Erdőfi-Szabó Ph.D., Chairman

If it seems that traditional and alternative methods are inefficient for healing, and even the natural healing procedures and dietary supplements fail, you should pay attention to the initial phase of a natural regeneration, your self-healing ability, or the lack thereof.

Several studies showed that the extremely low frequency and electromagnetic fields affect the passing of the neuronal action potential and can mimic the effects of the synaptic neurotransmitters. Although the extremely low frequency and electromagnetic fields can only create micro-volt size changes in the neuronal membrane potential, as a result of the signal mounting processes this can significantly influence the passing of the physiological action potential.

The computer-based method we apply in BioLabor, which regulates the patient's own control processes, was developed in house. It has helped over forty thousand people over a five-year period. It is based on natural self-regeneration, the improvement of the body's self-healing ability through cellular electro chemical balancing.

We use the human body's own, natural, electro- and electromagnetic impulses (similarly to ECG and EEG signals) which belong to the person's various biological processes. Our unique signal processing method is able to keep up with the pace of biological events, and instead randomly selecting certain moments, it can parallel and continually refine the body's self-regulation.

The Electromagnetic-Own-Signal-Treatment (the EMOST™ method) indicates the systematic diversion (extra-sense detection) and thematic recirculation of extremely low intensity, electric- and electromagnetic radiation that is based on the recorded natural, non-linear bioelectric and bio-electromagnetic signals (may potentials) of subjects. It influences the natural self-checking processes (regulation/adaptation) and the balance control of the electro-chemical processes (modulation of free radicals and antioxidants, redox processes as well as neurotransmission, and potentials/action potentials status) via the electro-chemical processes of the impulses and cellular receptors and free nerve endings. The detected non-linear own signals are processed in analog manner, then selected and reflected on the skin's surface. The state-of-the-arts EMOST method helps adjust and regulate directly the basic physiological flows of the body, organs and cells.

The EMOST™ method can potentiate the cellular metabolism, detection and immune processes in a natural way through the electric- and electromagnetic signals coming from the body's own range. By doing that it helps the biochemical homeostasis to recover, and helps for the neurovegetative system in signal transmission and signal recognising.



ELECTROMAGNETIC OWN SIGNAL TREATMENT

2012



The Company:

1. Scientific work, education, development of EMOST therapy
2. Clinical laboratory: serology, microbiology, tumourmarker etc., screening tests, electro-somatography
3. Factory medical services
4. Manufacturing of BioLabor EMOST Redox medical devices, service of EMOST therapy countryside, and sale of BioLabor franchise in Europe.
5. 7/7 Customer service, operation (since 2005, close to 70 BioLabor Health Center in 13 counties, and close to 40.000 satisfied customers with the BioLabor EMOST method).

ELECTROMAGNETIC OWN SIGNAL TREATMENT

2012

1. Supplement: Definitions

a, Physical Concepts

Atom: the smallest part of the chemical element that is not further divisible by chemical processes (MTA -Hungarian Science Academy's Explanatory Dictionary). An atom is the smallest quantity in chemistry that still preserves the chemical characteristics of the element. Atoms therefore are the fundamental components of molecules and the material.

Electron: the negatively charged elementary particle of the atom that is orbiting the nucleus, the elementary particle of electricity (MTA Explanatory Dictionary). The electrons together with the nucleus form chemical particles, and are responsible for the chemical bonds.

Ions: ion is an atom, or a molecule (atom group), that has an electric charge. The negative charged ion, in other words anion is such an atom or a molecule that has a surplus of one or more electrons; cation on the other hand is a positive charged ion that has a deficiency of one or more electrons the same way as in the original particle. The process along which ions are created is called ionization.

Frequency: The number of periods per one second. Frequency, density. Hungarian Science Academy (MTA)

Periods: regularly recurring sections of a certain phenomenon. (MTA Explanatory Dictionary).

Frequency of an electronic wave: the number of waveforms of electrical signals repeated per one second.

Magnetism: the characteristic of certain materials, atoms, molecules where electrons moving in the same direction generate a magnetic field between the materials.

Electricity: A physical process in which electric charges, their movements and effects can be found.

Electric charge: it is the characteristic of certain subatomic particles (namely the electron's and the proton's) that gets in touch with the electromagnetic field and attractive and repulsive forces occur between them. It is the fundamental feature left over in a few basic elements, which determines the extent to which it participates in the electromagnetic interaction, one of the fundamental interactions. The electrically charged material creates an electromagnetic field and the external electromagnetic field influences its movements.

Electric field: it operates between two electric charges similar to gravity between two objects. An essential difference between the two things is that gravity affects all objects, while the electric field comes into being only among electrically charged objects, on the other hand the force of the electric charges can also be repulsive. The force magnitude is inversely proportional to the square of the distance between the two charges, and is directly proportional to the size of the multiplied charges.

Electricity: it is the result of the flow of electrically charged particles. The particles can be positively or negatively charged. Examples for electricity can be the flow of electrons in metals (or in other conductive materials), or the power created in the electrolytes when charged ions flow in the liquid. The particles themselves are relatively slow physically, however, the electric field that creates the movement is practically moving at light speed.

Direct current (DC): when charged particles move only in a given direction.

ELECTROMAGNETIC OWN SIGNAL TREATMENT

2012

Electromagnetic interaction: the physics of the electromagnetic field. The electromagnetic field is the field which fills up the entire space created by the electric and magnetic fields. While the electric field is the result of the charge causing static electricity (that creates electricity in an electric conductor), the magnetic field comes from the movements of the electric charge (like the current in a conductor) and is manifested in the magnetic force similar to the permanent magnets. The change of the magnetic field creates an electric field called electromagnetic induction.

Electromagnetic power: It is the effect of the electric field on the particles of an electric charge. This type of force is one of the four fundamental forces of nature. The other three are the following: *1*) the strong nuclear force converging the nucleus, *2*) the weak nuclear force responsible for certain types of radioactive decay *3*) the gravitational force. All interactions (forces) between physical objects are the ultimate consequences of these 4 fundamental forces, however, the electromagnetic force is responsible for basically all the phenomena in our everyday lives, except for gravitation. All forces can be traced back to the electromagnetic force that affects the electrically charged protons and electrons of the atom., All chemical processes occur through the forces of the interactions of the electron's circulation.

Electromagnetic radiation: oscillating electric and magnetic field exceeding perpendicularly to each other that spreads in the space in the shape of a wave delivering energy and impulses with light speed. Its quantum are the photons. The electromagnetic radiation between the wavelength of 380 NM and 780 NM is visible to the human eye that's why we call it visible light. All the electromagnetic radiation can be arranged according to frequency (wavelength, energy), that is when we can get the electromagnetic spectrum. The physics of the electromagnetic radiation is described by electrodynamics.

Band-path filter: such an electric circuit, which operates in the pre-determined frequency range of electricity.

The ranges of the applied band-path filters via EMOST: 1-10Hz, 10-100Hz, 100-1kHz, 1kHz-10kHz, 10kHz-100kHz, 100kHz-1MHz, as 1-1.000.000 signal/sec.

Wave: state changes of a system that is periodic in time and/or space, IE has regular intervals. Apart from the electromagnetic wave, waves spread in some kind of a medium. They deliver energy without the constant motion of the material of the medium to the direction of propagation, thus the wave delivers energy resulting from motion coming from a stable point, but no mass.

Interference: a physical phenomenon that occurs if two coherent waves meet with different sources, IE waves whose phase difference is constant. As a result points come into being in space in which waves greatly strengthen each other, and also points in which waves greatly weaken each other (depending on what kind of phase difference the two waves arrive with at the individual points).

ELECTROMAGNETIC OWN SIGNAL TREATMENT

2012

b, Biological definitions

Homeostasis: Physiological concept, the ability to adapt to the external and internal changing conditions of the living organisms by which they can ensure their relative biological stability. Under the dynamic permanence and stability of the internal conditions we mean the proper nutrition-supply, the necessary quantity and quality of the respiratory gases, thermoregulation, the proper quantity and quality of the body fluids, volume, ion composition, pH, temperature, osmotic pressure, and the presence of all the protection modes, and the proper operation of all these. These components are ensured by the self-sustaining living organisms with the help of the hormonal and nervous system, collectively known as self-regulating operations.

Potential: The process of assisting the establishment of homeostasis.

Receptor: the organism or cells of the nervous system developed to collect stimuli. (MTA Explanatory Dictionary).

Free-radicals: Chemically very reactive atoms and molecules, which serve dominant signal roles in the physiological and pathological condition of the body. Free radicals are atoms or molecules that contain an unpaired electron on their external shells (having magnetic momentum), tend to form pairs and absorb more electrons from other molecules.

Signal process: It is a reflexive process based on stimulus perception and stimulus creation, under which we mean the organization and the operation of the subsystems, and the organization of the sub-systems with each other. This retrospective process is completed in atomic, molecular, cellular, electric- electromagnetic and electro-chemical ways in which the stimulus detection and the stimulus triggering have also a stimulus transmitting role.

Self regulation: it is a continuous regulation based on the control of the operations and the signal processes in order to have an overall homeostasis of the organization.

2. Bio-electrochemical knowledge to get a better understanding of the EMOST effects

"The cell membrane and its environment cannot be considered to be a balanced, closed system and the behavior of the individual ions are not independent. In resting position there is an ion flow maintained by constant electrochemical potential drops between the two sides of the cell membrane in a way that each ionic current density compensates one another. The ion concentration difference is constant between the outer and inner space, which is possible to maintain only with the help of the opposite direction active transport, i.e. operating the Na⁺ / K⁺ pump. The process continues until the ionic current created by the electric field is balanced with the diffusion current of the opposite direction.

An electric double layer is formed at the time of the dynamic balance so that the electric field and the opposite charge flows caused by the concentration differences can keep the balance with one another. „On the way” to the balance every state equals to a quasi-state characterized by the electrical neutrality of both sides - one by one - and also the temporary state between the distribution of the concentration and the ionic current.

ELECTROMAGNETIC OWN SIGNAL TREATMENT

2012

This balance is temporary, because it is true that the sum of the ionic currents is zero, but this is not fulfilled in the flow of certain ions one by one. Therefore the ion distribution changes over involving a change in the diffusion potential (Medical Biophysics, 3rd edition, p. 290, Medicina Publishing House).

We can further increase or decrease the resting membrane potential in a regulated way with the direction of the power (in absolute terms). The membrane gets hyperpolarized or depolarized accordingly. Regardless of the current direction, under the threshold response signals are obtained that are proportional with the power of the effect.

Above the threshold - in case of a depolarizing effect, the nature of the response sign is different from the previous one, and its size is independent from the fact of how much the inducing effect exceeds the threshold. This is the typical response of the so-called "Action potential" which characterizes the cell membrane excitability. (Medical Biophysics, 3rd edition, p. 290, Medicina Publishing House).

If the charge carried by the depolarizing currents (i.e. the proportional rate of the depolarization expressed in $mV \cdot s$) exceeds a certain threshold, the depolarization becomes independent of the size of the current pulse. The resulting voltage signal with ms duration is the action potential, which circulates with constant amplitude in the nerve or muscle fibers. The typical stages of the action potential during its course can be well-separated (Medical Biophysics, 3rd edition, p. 294 III.34a. Fig.)

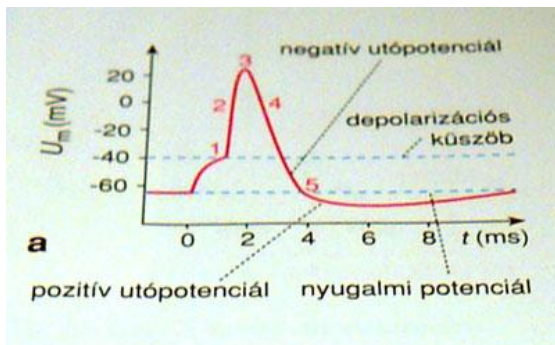

The voltage change during the action potential in the function of time and the change of the status of the voltage-sensitive ion channels in each section

1. Opening of Na^+ -channels
2. Opening of K^+ channels
3. Inactivating some of the Na^+ channels
4. Further outflow of K^+ , total closing of Na^+ channels
5. Closing of K^+ channels

ELECTROMAGNETIC OWN SIGNAL TREATMENT

2012

The electric model of the cell membrane (Medical Biophysics. 3rd edition, p. 292 III.32. Fig.)

Extra-cellular space

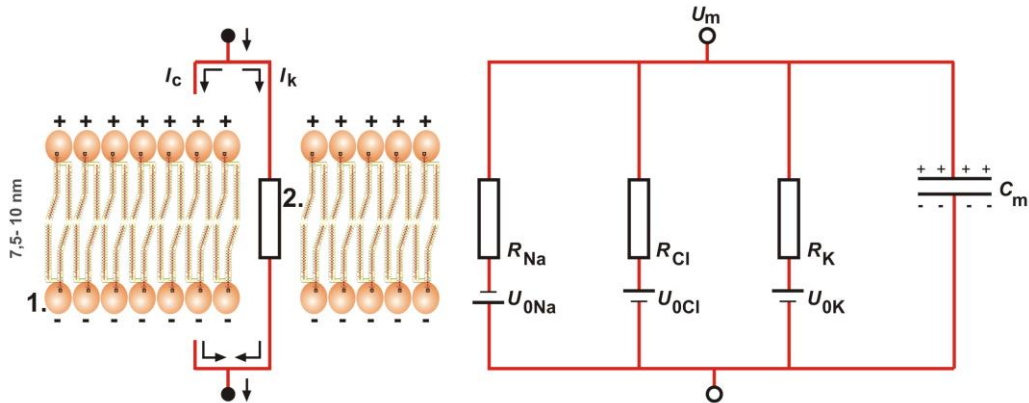

Intra-cellular space

1. Lipid double layer: capacity
2. Ion channel: resistance

The electric model of the membrane. The membrane can be described with transverse resistance (R_{Na} , R_{Cl} , R_K), with capacity (C_m) and with electric power (U_{0Na} , U_{0Cl} , U_{0K}).

The further improvement of the electric model of the cell membrane to interpret the effects of the pulse to the membrane (Medical Biophysics. 3rd edition, p. 293. III.32. Fig.).

Extra-cellular space

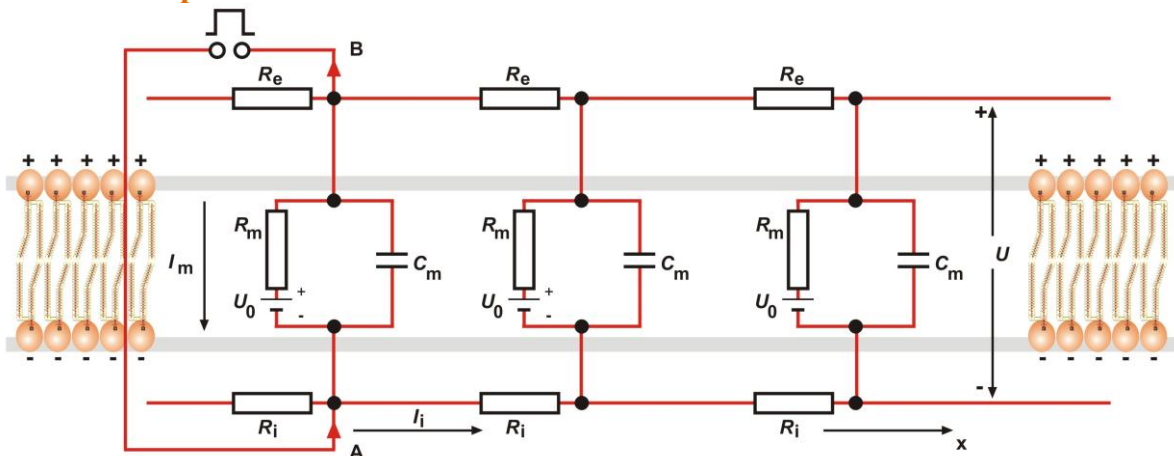

Intra-cellular space

ELECTROMAGNETIC OWN SIGNAL TREATMENT

2012

The electric model modified by Hodgkin, which regards the specific changing conductivity of the ion channels as opposed to the constant R_m (Medical Biophysics. 3rd edition, p. 295. III.35. Fig.).

Extra-cellular space

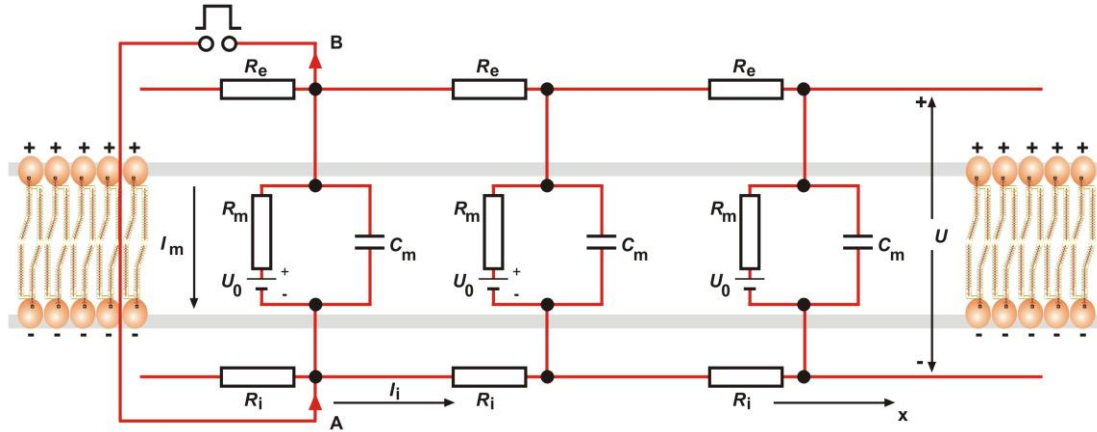

Intra-cellular space

In the course of the stimulated state, the permeability of the membrane changes with regard to Na^+ and K^+ ions for consideration of individual ions (Medical Biophysics. 3rd edition, p. 294 III.34b. Fig.).

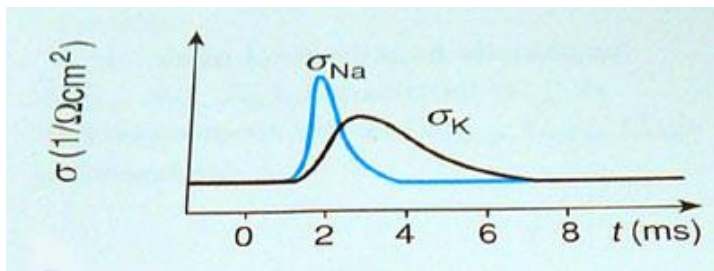

The typical changes of the specific conductivity of the voltage-sensitive Na^+ and K^+ channels during the action potential

During the membrane depolarization we arrive at a critical depolarizing value, when the voltage-controlled Na^+ channels begin to open. The increased Na^+ permeability constant shifts the membrane potential value toward the equilibrium potential of the appropriate distribution of the Na^+ , in accordance with the Goldman-Hodgkin-Katz equation leading to further depolarization. As a result, large amounts of Na^+ ions flow towards the intracellular space in accordance with the concentration drop. The presence of Na^+ ions shifts the negative potential of the intracellular space toward zero, therefore, the depolarization increases.

ELECTROMAGNETIC OWN SIGNAL TREATMENT

2012

This Hodgkin-cycle is a typical example of a positive feedback when a change in the system's operation reacts to the system itself in a way that it increases the primary change rate. The cell next to the fully open Na⁺ channels would travel toward the so-called "resting" state if the open state of the channels was a stable conformation. However, it does not occur as the Na⁺ channels are automatically deactivated. In an inactive state, the channels do not hold the stimulus threshold of the cells, which is infinitely large, and the cell cannot be irritated in such a refractory state.

The K⁺ channels are created by the depolarization by opening the Na⁺ channels, however, these channels begin to operate with a delay compared to the Na⁺ channels. In such circumstances, the Na⁺ permeability reduces even more while the K⁺ permeability increases. The active pump pumps K⁺ ions into the cell, and pumps Na⁺ ions out of the cell. As a result of all these processes the original resting state returns and due to delayed closure of the K⁺ channels a transient hyper-polarization occurs. The mechanism, which restores the resting potential, functions on the basis of the principle of negative feedback. After the closure of the K⁺ channels, the Na⁺ channels get into a simple closed state from an inactivated state. In this state, the cell can be irritated again, but its stimulus threshold is higher than at rest (relative refractory phase) (Medical Biophysics. 3rd edition, p.295, 296).

If the Na⁺ channels open as a result of the depolarization in a definite part of the cell membrane, then the action potential is developed. As the cell membrane is surrounded on both sides by the principal electrolyte, the local electro gradient changes and spreads to all directions. The amplitude of the changes decreases rapidly as the distance increases due to the resistance of the medium during its spread, so we could expect that the action potential is a local phenomenon induced in a well-defined place (i.e. it is greatly diminishing during expansion). If that was really the case, the action potential would be inadequate to help the information flow between the remote parts of the body. In fact, the action potential can spread along the membranes of the neurons (including the axon membrane as well) without any weakening. The required strengthening ("relay station features") is provided by the opening of the voltage-controlled Na⁺ channels. Depolarization might occur according to the rules of exponential decay (see III/4.3.2.) controlled by the space-constant in the adjacent regions of the place of the action potential.

This depolarization can reach such an extent in the close regions compared with the 90mV potential at rest, that the value of the membrane potential can reach -30-40 mV (depolarization threshold). This value is sufficient to open the voltage-controlled Na⁺ channels. Given that the closing of the Na⁺ channels is followed by a 1 ms long inactivated state, during which the channels are not able to be opened, the action potential spreads in one direction only (not "backwards"!). As a result of the cessation of the refractory state, the depolarization wave is at a distance that its effect does not reach the stimulation threshold. In case of irritable mammalian cells, the velocity of the action potential can drop between 1 m /s and 30 m/s (Medical Biophysics. 3rd edition, p.296, 297).

ELECTROMAGNETIC OWN SIGNAL TREATMENT

2012

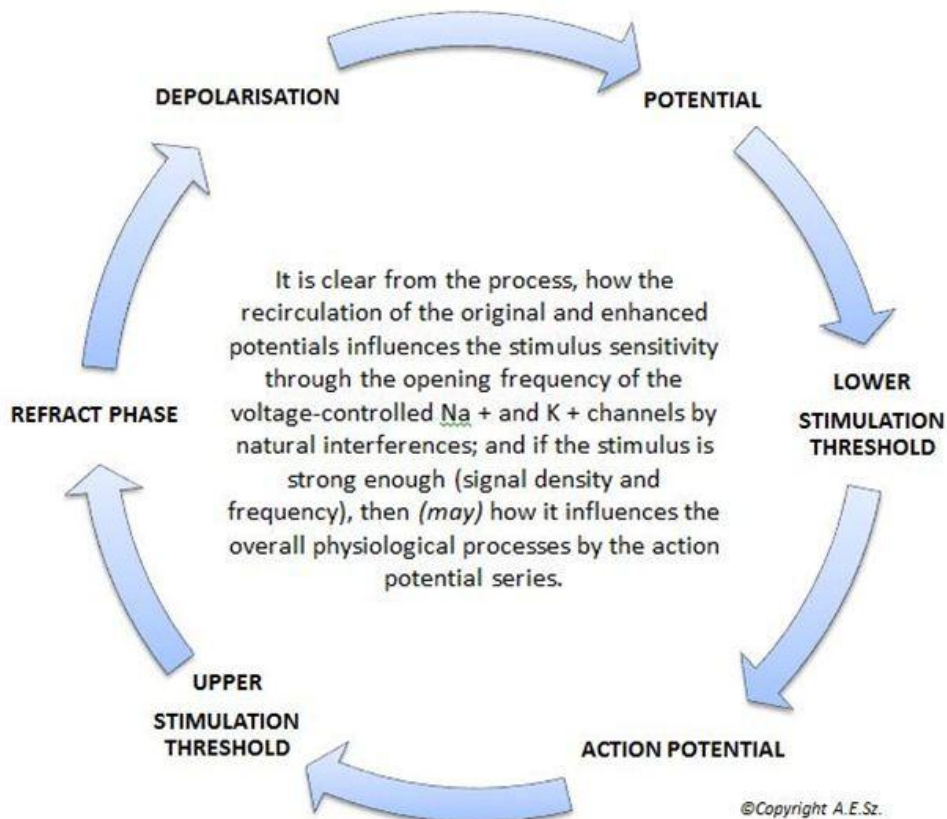

Sense organs are such units of the body, which collect information from the outside world, as well as information from the inner state of the body, and convey this information to the central nervous system. Information is collected by millions of microscopic structures, called receptor cells. These can be found in almost every part of the body, in the skin, in the muscles, in the joints, in the inner organs, in the walls of the blood vessels, and in the specific sense organs, like the eye or the inner ear. Receptors are generally "specialized" to a specific stimulus effect, i.e. a certain wavelength range of the light, molecules of defined shapes, vibration or even temperature. In a stimulated state, the neuron connected to the receptor cell begins to "burn", i.e. electrical impulses and a series of action potentials are generated. The nerve fiber transmits the information in the way described above to the spinal marrow and also to the brain. Most of the action potential series gets to a special part of the cerebral cortex through metastases, where certain stimuli can be found separately in different places. The final processing of the information is the responsibility of the associative cortical areas (Medical Biophysics book. 3rd edition, p.301, 302.).

The receptors found in the skin can be considered analogue signal converters, which transform the sensed stimulus into an electro signal, a change in the membrane-potential. It is the so-called receptor- or generator potential. The receptor nerve transforms the stimuli over the threshold into a series of action potentials, the frequency of which is the function of the receptor potential. This "frequency-coded" pulse-sequence runs along the axon until it reaches the sensory center of the cortex (Medical Biophysics 3rd Edition, p. 303).

ELECTROMAGNETIC OWN SIGNAL TREATMENT

2012

BIOLABOR *Emost Redox 1.1*

The EMOST™ method influences the subject's basic electrochemical, physiological processes by conducting, selecting, expanding, transmitting and redirecting the subject's own, different signal density potential and action potential.

The conducted action potentials buried in noise with different signal density (signal density/sec, means frequency) are supplemented by their amplified / attenuated (-20 dB, 60 dB) and harmonic (5 MHz) versions (further enhanced potency) and then they get re-circulated on the skin surface in a thematic way. If the stimulus is below the stimulation threshold or the relative threshold is high, or sensitivity to stimuli is decreased, the stimulus is not able to elicit action potential and the stimulus remains without reaction.

The recirculation of the original and enhanced potential affects the opening frequency and the stimulus-sensitivity of the voltage-controlled Na + and K + channels. If the stimulus strength is sufficient (signal density, frequency), then the action potentials, which are thus not confined to the direct location of the stimulation but spread in the whole tissue, get to the spinal cord through metastasis, or to the cortical association areas where certain stimuli are formed separately, then they get processed.

The nerve impulse (pulse, action potentials), the electro-negativity wave spreading from the initial part of the axon, moves rapidly along the surface of the membrane (axolemma). Stimulation alters the Na + ion permeability of the membrane and Na + ions flow in the axon. This transport consumes energy, which is provided by the adenosine triphosphate (ATP). The number of positive ions on the outer surface of the axolemma rapidly decreases to zero. As a result the membrane potential drops to zero too, i.e. it gets depolarized. A typical resting potential is -80 mV in a way that the surface of the outer membrane is electro-positive compared to the internal surface; the action potential is about +40 mV in a way that the outer surface of the membrane is electro-negative compared to the inner surface.

The action potential in the thinner axons may be less than 40 mV. The negatively charged part of the outer surface of the axolemma affects the adjacent positively charged part of the axolemma as a stimulus, and the adjacent action potential at rest transforms into action potential in less than 1 ms. In this way, the action potential passes along the nerve fibers, exactly to their end. As the action potential moves along the nerve fibers (axons, dendrites), the entry of Na + ions into the axona ceases and the axolemma permeability relative to K + ions increases. Then K + ions flow to the outer surface of the axolemma, so the resting membrane potential is restored.

The discharge begins on the axon hill, then through the axon, reaching the end of it as it arrives in a synapse, where it leads to the creation of new neurotransmitter molecules and by contacting the dendrites of the neighboring cells it can induce their filling. This process continues until the stimulus reaches a specific cell (such as a muscle moving cell in case of an efferent signal sequence).

ELECTROMAGNETIC OWN SIGNAL TREATMENT

2012

The electrical signal is conducted through the cell body and the axon strings. Insulation is produced by special glial cells (Schwann cells) covering the axon. In case of the central nervous system the oligodendrocytes produce the insulation and they do the maintenance as well. The conducting consists of a series of discharges of the pieces after they are fully charged. The charge transfer takes place from gap to gap with a series of bounces, through the so-called saltatorial conducting. (Thus, if the original potential is not high enough, or there is a large loss due to the failure of insulation, then the signal or instruction is not received, which causes a disease of the body, e.g. Amyotrophy lateralsclerosis).

After a nerve stimulus passes the nerve fiber while the axolemma is depolarized, a second stimulus, even if it is strong will not be able to generate a stimulus in the nerve (refractory period). The neurons of the nervous system form a functional conducting field while connected to each other. Where two neurons are in close proximity and a functional relationship appears between them, a synapse is created. A chemical neurotransmitter is released on the presynaptic membrane of the synapse, through which the synaptic gap connects to the specific receptors of the postsynaptic membrane, and stimulates (or prevents) the next neuron (dendrite) and creates a stimulus shift at the effector endings of the peripheral nervous system.

All the neurotransmitters playing the role of opening and closing channels of the neuron wall have different effects and characteristics. The catalyst, stimulating ones, such as acetylcholine, the ones with glutamate and serotonin compounds mostly effect the state of the Na⁺, K⁺ and Ca²⁺ cations' channels; while the GABA and glycine compounds that are mainly blockers and inhibitors have an effect on the Cl⁻ anion channel. The latter two play the main role in the neurons of the brain.

As an effect of the action potential, the content of the vesicles gets into the intracellular space, and activates the glutamatereceptors in the postsynaptic cell (e.g. NMDA-receptor). Glutamate is the anion of an amino acid, the Glutamic acid (abbreviated as Glu or E). It has a single, negative charge, it is stored in the vesicles, the presynaptic cell of the neural synapses, and it plays a crucial role in the removal of the nitrogen, it gets deaminated, and as a result an oxidative reaction is created, which is catalyzed by a glutamate dehydrogenase enzyme. Glutamate is the most common excitatory neurotransmitter in the nervous system. It is fundamental in the systematic responses to stress; therefore in its absence the body's immune reactions are impaired. It plays a key role in many metabolic and immunological processes, also the most important energy source for rapidly dividing cells, such as the enterocytes, lymphocytes. It reduces the production of the inflammatory mediators and enhances that of the antiphlogistic ones, and it also enhances cellular immunity. In addition, it increases the barrier function of the intestinal tracks, and a major role is assumed in the process of learning and memory formation.

The nerve stimulus reaches the spinal cord through the afferent neurons. The afferent fibers form a synapses in the spinal cord, (for example) with the large alpha motor cells, - located in the anterior horns of the gray matter of the spinal cord, and the nerve stimulus spreads further along the efferent motor fibers, then it stimulates the work muscle fibers at the motor end plate (neuromuscular junction).

ELECTROMAGNETIC OWN SIGNAL TREATMENT

2012

It is clear from the process -by natural interferences, how the recirculation of the original and enhanced potentials influences the stimulus sensitivity through the opening frequency of the voltage-controlled Na + and K + channels; and if the stimulus is strong enough (signal density and frequency), then how it influences the overall physiological processes by the action potential series.

Conclusion



The special analog signal processing of the EMOST™ equipment allows much more length of the detected electromagnetic and regenerated electromagnetic signal information than in the digital (signal loss, signal distortion) cases. The EMOST™ method seems to be able to potentiate cellular communication, the control processes and the operation of the biochemical homeostasis in a natural way by reflecting the electric- and electromagnetic impulses coming from the body's own range, all without the use of any artificial electric- and electromagnetic radiation, and the risks thereof.

On the basis of the experiments so far (see own Bibliography) one of the likely impacts of the EMOST™ method works through the potentiation and balancing of the bio-electro-chemical / redox processes and through intensifying the cellular communication.

EMOST – EM Own Signal Therapy



The biological basics



Light is very strange. Sometimes it is best to think of light as a series of waves. At other times, it is useful to think of light as a swarm of particles. When we think of light as particles, we call those particles of light "photons".

Photons are the carriers of all forms of **electromagnetic (EM) radiation**, not just light. The different types of EM radiation correspond to different amounts of energy per photon. **Gamma ray** and **X-ray** photons have the most energy, **radio frequency photons** have the least energy, while **ultraviolet**, **infrared**, and **visible light** photons have intermediate energies.

Photons travel at the speed of light, which is 299,792,458 kilometers per second (about 186,282.4 miles per second)! **Photons don't have any mass, nor do they carry an electrical charge**.

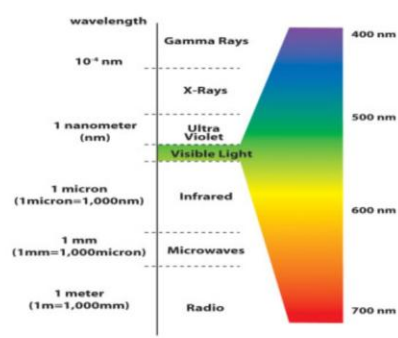

Visible light is one way energy uses to get around. Light waves are the result of vibrations of electric and magnetic fields, and are thus a form of **electromagnetic (EM) radiation**. Visible light is just one of many types of EM radiation, and occupies a very small range of the overall **electromagnetic spectrum**. We can, however, directly sense light with our own eyes, thus elevating the role of this narrow window in the EM spectrum because of its significance to us.

Light waves have **wavelengths** between about 400 and 700 nanometers (4,000 and 7,000 Å). Our eyes perceive different wavelengths of light as the rainbow hues of colors. Red light has relatively long waves, around 700 nm (10⁻⁹ meters) long. Blue and purple light have short waves, around 400 nm. Shorter waves vibrate at higher frequencies and have higher energies. Red light has a frequency around 430 terahertz, while blue's frequency is closer to 750 terahertz. Red **photons** carry about 1.8 electron volts (eV) of energy, while each blue photon transmits about 3.1 eV.

CLASS	FREQUENCY	WAVELENGTH	ENERGY
Y	300 EHz	1 pm	1.24 MeV
HX	30 EHz	10 pm	12.4 keV
SX	3 EHz	100 pm	12.4 keV
SX	300 PHz	1 nm	1.24 keV
EUV	30 PHz	10 nm	12.4 eV
NUV	3 PHz	100 nm	12.4 eV
NIR	300 THz	1 μm	1.24 eV
MIR	30 THz	10 μm	12.4 meV
FIR	3 THz	100 μm	12.4 meV
EHF	300 GHz	1 mm	1.24 meV
SHF	30 GHz	1 cm	12.4 μeV
UHF	3 GHz	1 dm	12.4 μeV
VHF	300 MHz	1 m	1.24 μeV
HF	30 MHz	10 m	12.4 neV
MF	3 MHz	100 m	12.4 neV
LF	300 kHz	1 km	1.24 neV
VLF	30 kHz	10 km	12.4 peV
VF/ULF	3 kHz	100 km	12.4 peV
SLF	300 Hz	1 Mm	1.24 peV
ELF	30 Hz	10 Mm	12.4 feV
ELF	3 Hz	100 Mm	12.4 feV



Visible light's neighbors on the EM spectrum are infrared radiation on the one side and ultraviolet radiation on the other. **Infrared radiation** has longer wavelength waves than red light, and thus oscillates at a lower frequency and carries less energy. **Ultraviolet radiation** has waves with shorter wavelengths than do blue or violet light, and thus oscillates more rapidly and carries more energy per photon than visible light does.

Light travels at the incredible speed of 299,792,458 kilometers per second (about 186,282.4 miles per second). At this amazing speed, light could circle Earth more than seven times in one second! The lowercase letter "c" is often used to represent the speed of light in equations, such as **Einstein's** famous relation between energy and matter: "E = mc²". All forms of electromagnetic waves, including **X-rays** and **radio waves** and all other frequencies across the EM spectrum, also travel at the speed of light. Light travels most rapidly in a vacuum, and moves slightly more slowly in materials like water or glass.

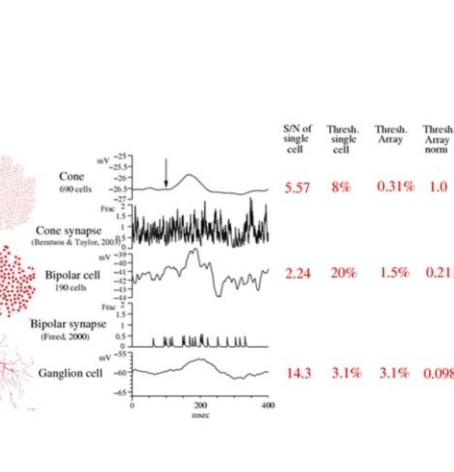
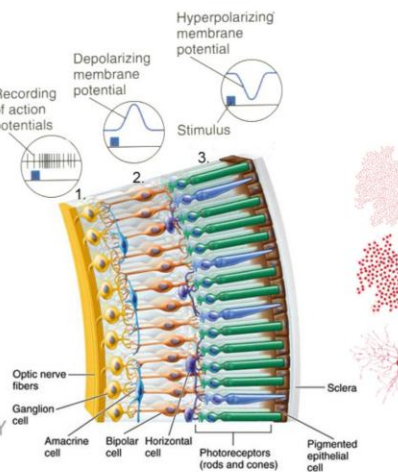
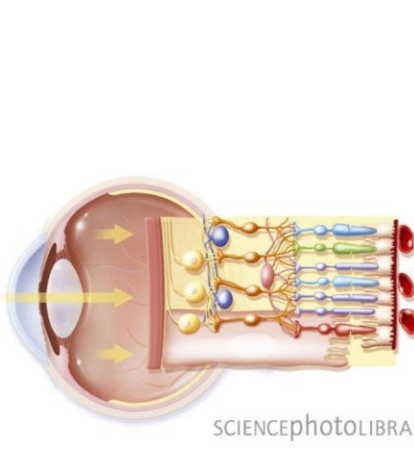
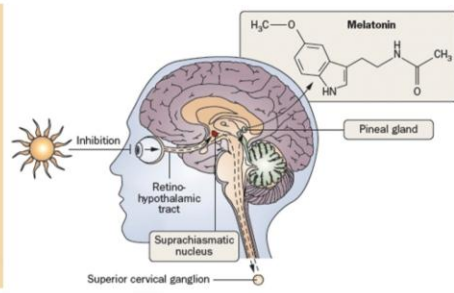

Own Signals

- Actions Potentials -

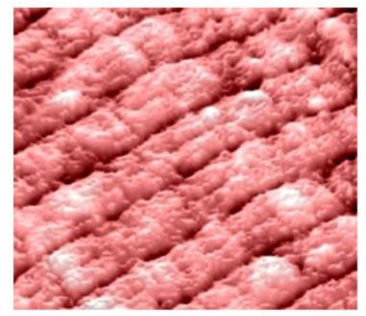
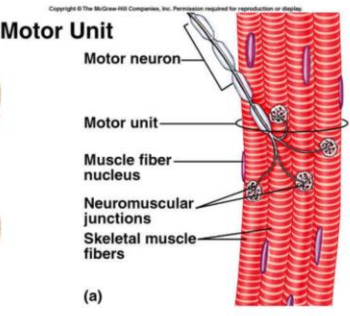
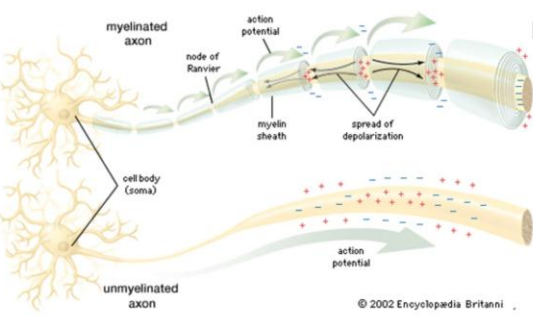
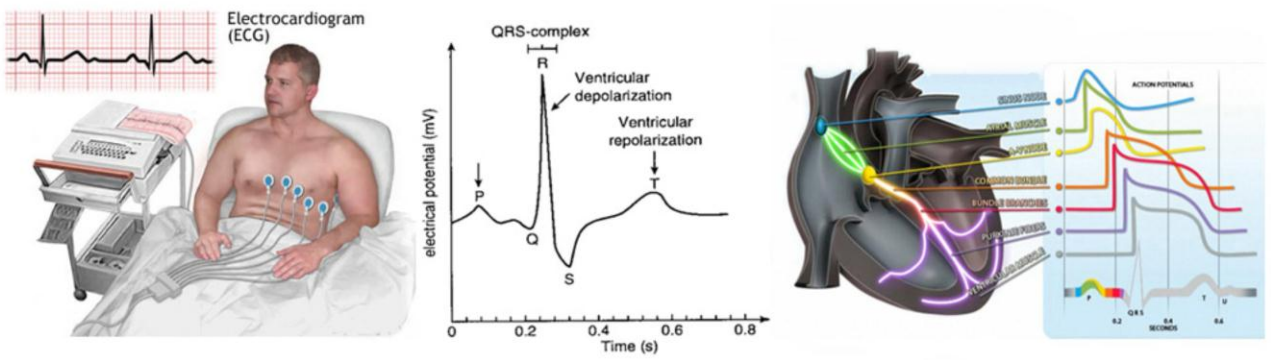
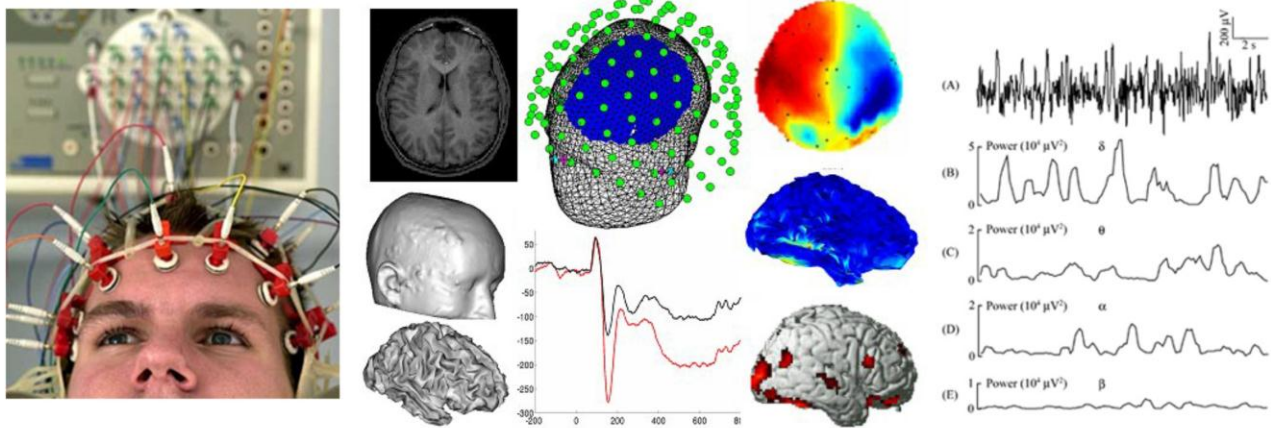

ELECTROMAGNETIC OWN SIGNAL TREATMENT

2012

Illustration: K. Seetharaman, H Namazi - Arxiv preprint arXiv: 1204.0574, 2012, Neuroscience: Phase lagging model of brain response to external stimuli - modeling of single action potential.

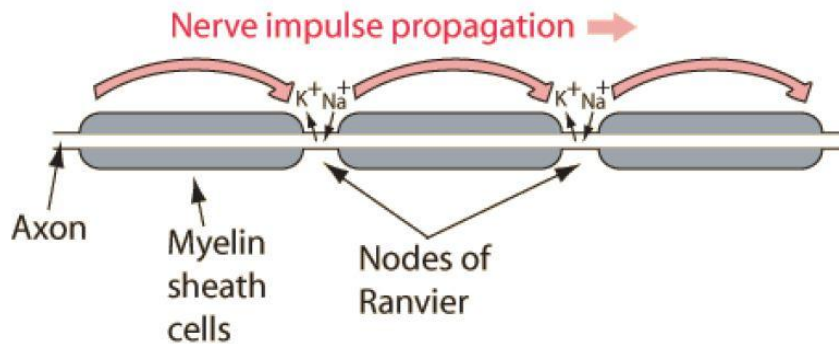

Figure. 1. Schematic structure of a typical axon

Illustration: K. Seetharaman, H Namazi - Arxiv preprint arXiv: 1204.0574, 2012, Neuroscience: Phase lagging model of brain response to external stimuli - modeling of action potential in a neuron

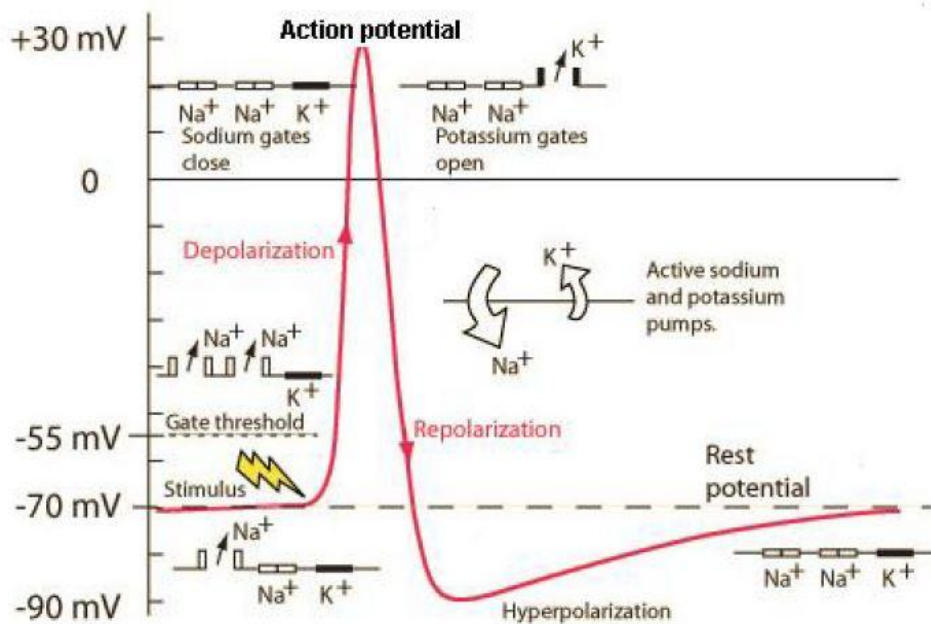

Figure. 2. Action potential generation in a neuron

ELECTROMAGNETIC OWN SIGNAL TREATMENT

2012

A short introduction about EMOST™

Our method is called EMOST™ (Electromagnetic Own Signal Therapy)



The EMOST Redox 1.1 medical device

Well, what the very special features are of our EMOST™ method compared to numerous electromagnetic devices over the world. Diverse electromagnetic curing devices over the world employ various artificial electromagnetic signals that are mainly modulated with respect to the frequency or the amplitude.

Because it is impossible to investigate the whole range of artificial electromagnetic frequencies for therapeutic applications, it seemed reasonable for us to **use non-linear own bioelectric and bioelectromagnetic signals from skin cells of patients for therapeutic applications**, which can be much more effective than the diverse, artificial electromagnetic signals. Our EMOST™ system can detect and sense non-linear, bioelectromagnetic signals (may potentials) of the patient's skin **in extrasense range** 1 to 1.000.000 signal/sec/mV.

Natural, non-linear signal (potential)

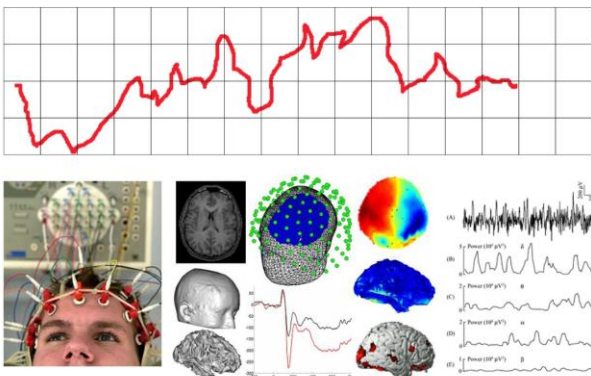

Non-linear own body bioelectromagnetic signals

Synthesized (non-natural), linear signals

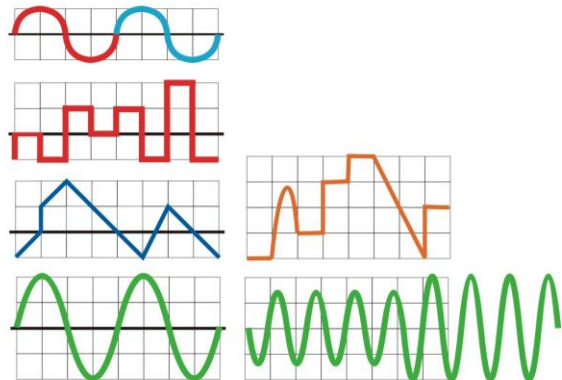

Artificial electromagnetic signals

ELECTROMAGNETIC OWN SIGNAL TREATMENT

2012

The collected bioelectromagnetic input signals from patients' skin are processed by preprogrammed EMOST device. The patients are treated by preprogrammed signals of EMOST device (frequencies in the range of 1-1,000,000 signal/sec (Hz); intensity range between 1-10 micro Teslas, mV, via special extreme sense input/output flat electrode-antenne).

The next very special feature is of our EMOST™ method compared to many electromagnetic devices over the world that **detected own bioelectromagnetic signals from skin are processed, inside EMOST device, via analogue manner (natural based, non-digitalized!)**, which are transmitted back via a special flat electrode through different (BioLabor know-how) band/signal combinations, with some amplification (-20dB- +60dB), to the skin's surface on the opposite side, extended by the higher range (Fourier transformations) of the signal. The extended range natural based signals helps with interference for activity of potentials and action potentials. (See attached publications on CD)

 The special analogous signal process of EMOST™ device makes it possible that the information content of detected and back-transmitted electromagnetic signal is much coherenced than in digitized cases, so helps for natural potentials to be in action potentials.

Natural, non-linear signal (potential) Non-coherence, (likely) aggressive stimuli via synthesized EM signal
(may) first step in the EM therapies only, (may) high level of risk or uncalculated effects
(may) needs hard re-coordinating of the biological system

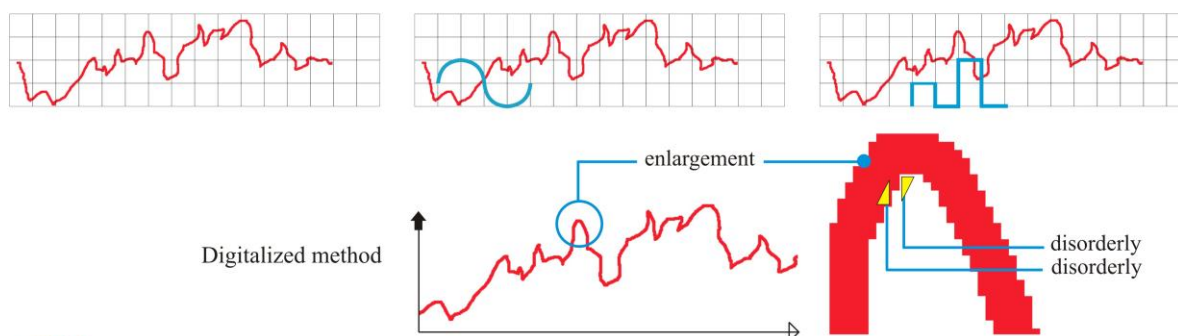

BIOLABOR *Emost Redox 1.1*

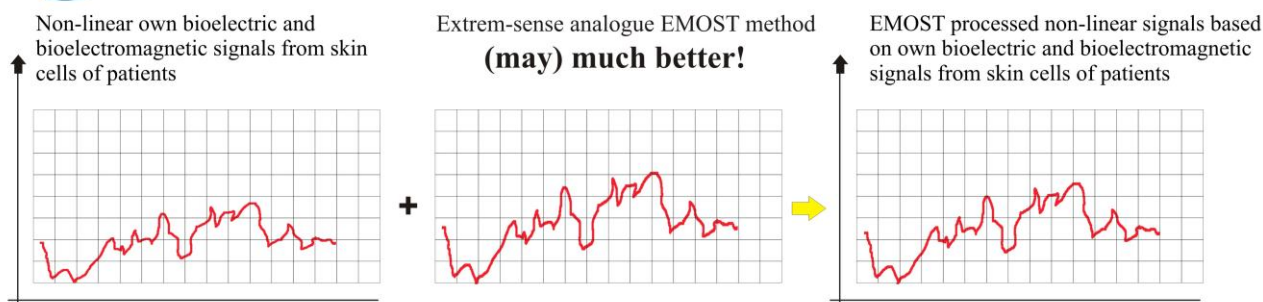

We should see that during various diseases, living cells not only demonstrate altered and impaired biochemical processes but also produce altered non-linear bioelectromagnetic complex patterns. Since each patient has a unique description concerning his/her own particular diseases, bioelectromagnetic own signals from skin cells of patients for therapeutic applications can be much more effective than the any diverse, artificial electromagnetic signals.

ELECTROMAGNETIC OWN SIGNAL TREATMENT

2012

 Our EMOST™ device can guarantee this specific method, because its output signals are based on the appurtenant bioelectromagnetic signals of the patients' own living systems.

Over the last 6 years, in many cases, while pharmacologic treatments were ineffective, our EMOST application was able to help patients. In addition, we perform continuously various clinical experiments by EMOST™ devices and publish them in peer-reviewed scientific journals. Consequently, the EMOST™ is a state-of-the-arts scientific medical method in self-recovering.



Our scientific publications about EMOST

- Bókkon I., Till A., Erdőfi-Szabó A. (2011) Effect of Electromagnetic-Own-Signal-Treatment on electrocardiogram and the concentration of urea, cholesterine, albumin, cortisol, creatin, TSH, CRP in serum. Under processes.
- Bókkon I., Till A., Grass A., Erdőfi-Szabó A. (2011) Phantom pain reduction by electromagnetic treatment. Electromagnetic Biology and Medicine In press
- Bókkon I., Till A., Erdőfi-Szabó A. (2011) Non-ionizing Electromagnetic-Own-Signal-Treatment. 8th European Biophysics Congress. 23-27 August, Budapest, Hungary.
- Bókkon I., Till A., Erdőfi-Szabó A. (2010) Phantom Pain Reduction by Non-ionizing Electromagnetic Treatment. International Conference of Preventive Medicine and Public Health. 19-20 Nov. Pécs, Hungary.
- Bókkon I., Till A., Erdőfi-Szabó A. (2010) Phantom Pain Reduction by Non-ionizing Electromagnetic Treatment. Available from Nature Precedings <<http://dx.doi.org/10.1038/npre.2010.4989.1>> (2010)
- Bókkon I., Till A., Erdőfi-Szabó A. (2010) Phantom Pain Reduction by Non-ionizing Electromagnetic Treatment. Hungarian Epidemiology 7/4/Suppl. p:15. Abstract
- Bókkon I., Erdőfi-Szabó A., Till A., Balázs R., Sárosi Z., Szabó Z.L., Kolonics G., Popper G. (2012) EMOST: Report about the application of low-frequency and intensity electromagnetic fields in disaster situation and commando training, Electromagnetic Biology and Medicine, In press

ELECTROMAGNETIC OWN SIGNAL TREATMENT

2012

Effects of the EMOST on biochemical and physiological mechanisms

- a) (the organs deep inside the body are being effected via the easily accessible surface of the skin, as a result of the cells' internal and external bioelectrochemical processes)
- b) the radiation in its natural range potentiates the subsystems of the body
- c) helps the fine modulations in the central nervous system processes
- d) affects the parasympathetic / sympathetic balance of the neurovegetative system
- e) affects the cellular signal processes (potentials, action potentials)
- f) affects the neuro-endocrin operation
- g) facilitates hormonal control
- h) helps the immune processes
- i) affects the control of free radicals and the antioxidant level (redox processes)
- j) affects the control of the acid-base balance (pH)
- k) helps the homeostasis of the body in its natural range

Example about extremely low-intensity electromagnetic radiation induced bio-chemical processes in cells: electromagnetic radiation (exposition) → changes in the structures of the membrane receptor → activation of NADPH oxidase at plasma membrane → production of super oxide radicals $O_2^{\cdot-}$ → activation of calcium Ca^{2+} channels and lipoxygenase → stimulation of the arachidonic acid cascade → peroxidated lipids → extension of intracellular signals.

Some relevant references:

- Morabito C, Rovetta F, Bizzarri M, Mazzoleni G, Fanò G, Marigliò MA. Modulation of redox status and calcium handling by extremely low frequency electromagnetic fields in C2C12 muscle cells: A real-time, single-cell approach. *Free Radic Biol Med.* 2010, 48: 579–589.
- Nindl G, Balcavage WX, Vesper DN, Swez JA, Wetzel BJ, Chamberlain JK, Fox MT. Experiments showing that electromagnetic fields can be used to treat inflammatory diseases. *Biomed Sci Instrum.* 2000, 36: 7-13.
- Ke XQ, Sun WJ, Lu DQ, Fu YT, Chiang H. 50-Hz magnetic field induces EGF-receptor clustering and activates RAS. *Int J Radiat Biol.* 2008, 84: 413-420.
- Simkó M. Cell type specific redox status is responsible for diverse electromagnetic field effects. *Curr Med Chem* 2007, 14: 1141-1152.
- Cook CM, Thomas AW, Keenlside L, Prato FS. Resting EEG effects during exposure to a pulsed ELF magnetic field. *Bioelectromagnetics* 2005, 26: 367-376.
- Ryczko MC, Persinger MA. Increased analgesia to thermal stimuli in rats after brief exposures to complex pulsed 1 microTesla magnetic fields. *Percept Mot Skills.* 2002, 95:592-598.
- Selvam R, Ganesan K, Narayana Raju KV, Gangadharan AC, Manohar BM, Puvanakrishnan R. Low frequency and low intensity pulsed electromagnetic field exerts its antiinflammatory effect through restoration of plasma membrane calcium ATPase activity. *Life Sci.* 2007, 80: 2403-2410.
- Johnson MT, Waite LR, Nindl G. Noninvasive treatment of inflammation using electromagnetic fields: current and emerging therapeutic potential. *Biomed Sci Instrum.* 2004; 40: 469-474.

ELECTROMAGNETIC OWN SIGNAL TREATMENT

2012

How output signals from EMOST device can reach to all parts of body



1. EMOST-sensor 2. skin 3. epidermis 4. dermis 5. fat 6. blood wessels 7. sweat gland
8. receptors 9. free nerve endings 10. nerve 11. neuropeptides 12. fybroblasts, keratnocytes
13. hormones 14. proteases, cytokines 15. Merkel-cells, local immun system

⚠ EMOST™ method can convey the detected and changed bioelectromagnetic patterns of effective cells to surrounding and other cells, which facilitates intercellular communication via biochemical processes, and helps in signal transmission and recognizing of neurovegetative system. Specifically, EMOST™ method can affect the length of cell membranes and the number and variety of membrane-bound receptors and signal transmission..

- I. **First signal way:** Output signals from EMOST™ via a flat electrode can influence bioelectrochemical and redox processes of blood circulation of arterial and capillary systems under the skin thus output signals can reach to all parts of our body.
- II. **Second signal way:** Output signals from EMOST™ via a flat electrode can influence terminal nerves and sensory receptor cells in the skin. Excited fibres of sensory skin receptor cells convey the EMOST™ induced signals to spinal nerves or cranial nerve, which can modify membrane and action potentials.
- III. **Third signal way:** Output signals from EMOST™ via a flat electrode can influence immune system of skin. It is less known that there is twice as much T cells in our skin than in our circulation blood. However, according to latest scientific results, the skin works as a neuro-immuno-endocrine organ.
- IV. **Forth signal way:** Output signals from EMOST™ via a flat electrode can influence terminal Merkel cells the skin, as a bipolar electro-accupuncture effect –with non-invasive. The Merkel cells modify the ATP activity. The ATP-activated sensory nerves also lead to modulation of the activity of brain-stem neurons controlling autonomic nervous system functions of gut, lung, urogenital, and cardiovascular systems—all of which have been treatment targets for traditional acupuncture procedures.

ELECTROMAGNETIC OWN SIGNAL TREATMENT

2012

Illustration: Third signal way:

The skin as a neuroimmunoendocrine organ. *Physiol Rev.* 2006 86(4):1309-1379

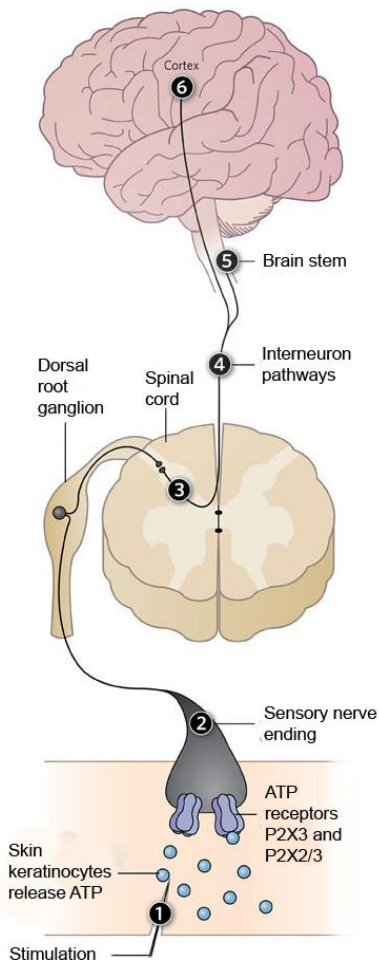
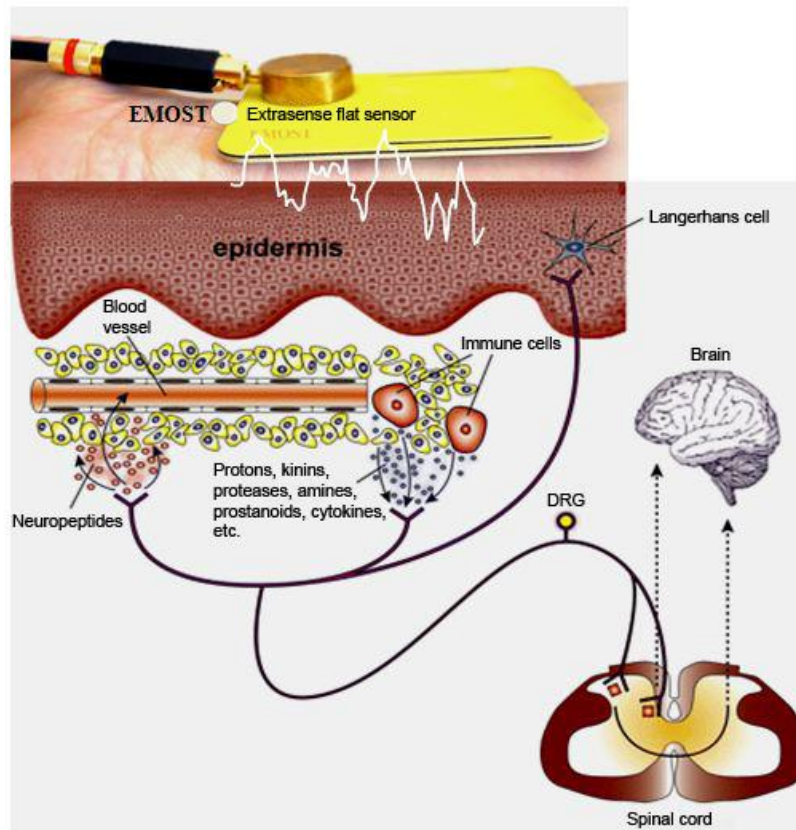

Illustration: Fort singal way:

Signal leading to the release of ATP by skin keratinocytes (1). ATP binds to specific receptors located on sensory nerve endings in the skin known as P2X3 and P2X2/3 (2). The signaling message is then relayed via dorsal root ganglia to the spinal cord (3) and subsequently through interneuronal pathways (4) to the brain stem (5) which contains motor neurons that control the functions of gut, lung, heart, arteries and reproductive organs, and the signals also travel to signal centers in the cortex, delivering a message to inhibit flow (6).

<http://the-scientist.com/2011/09/01/puncturing-the-myth>

Figure source: Roosterman et al. Neuronal control of skin function:

The EMOST[®] process

transmitting the natural based extrem-low intensity analogue signals back in natural range

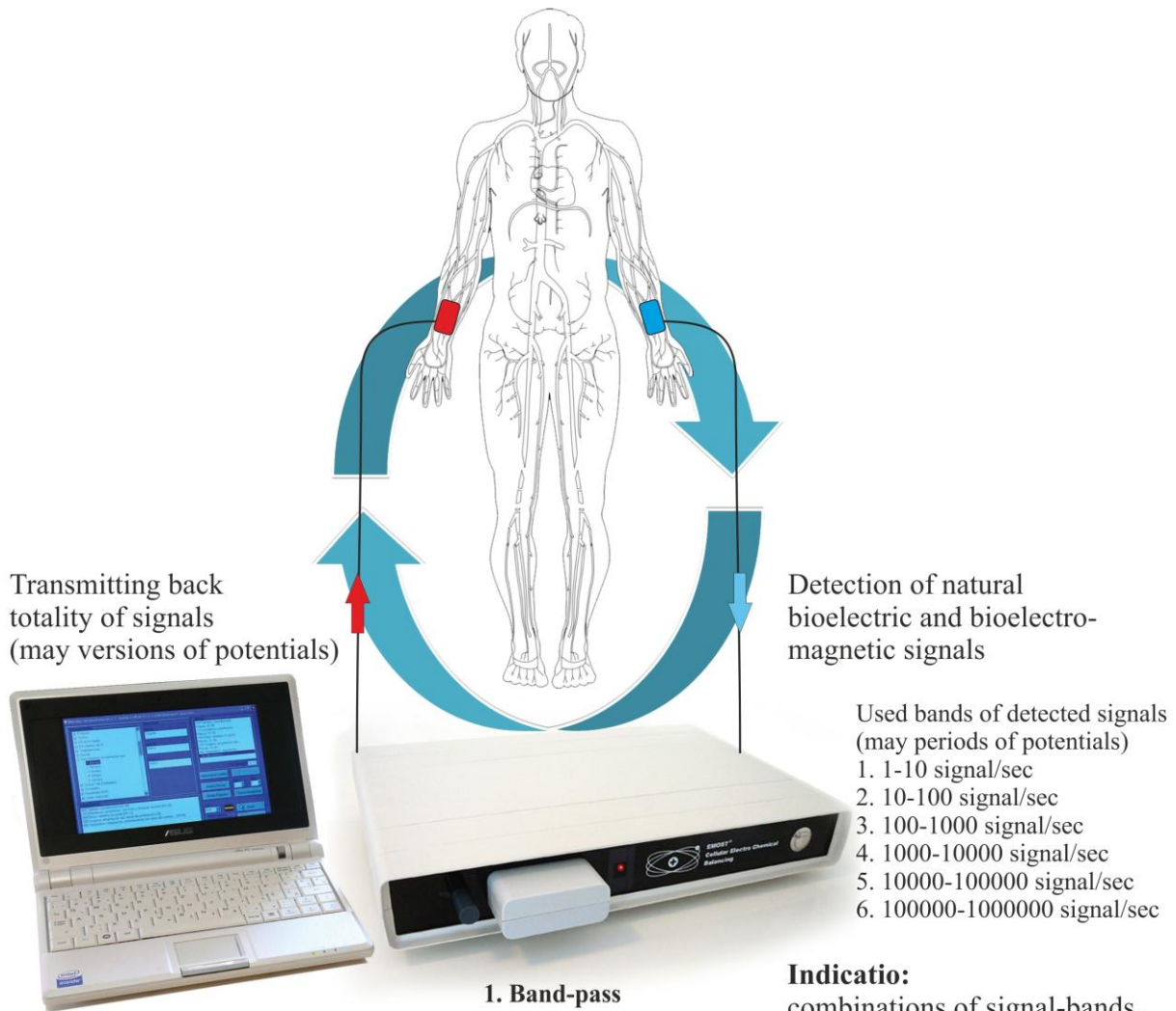

Transmitting back totality of signals (may versions of potentials)

Detection of natural bioelectric and bioelectromagnetic signals

Used bands of detected signals (may periods of potentials)

1. 1-10 signal/sec
2. 10-100 signal/sec
3. 100-1000 signal/sec
4. 1000-10000 signal/sec
5. 10000-100000 signal/sec
6. 100000-1000000 signal/sec

1. Band-pass
2. Amplification

-20 dB,
60 dB

3. Expansion, and extension of variations

Fourier transform
-14 dB to 5 MHz
0,1 sec. – 102 sec

Indicatio:

combinations of signal-bands, variations of amplification and extension of variations



Developer/owner: EMOST Nano-MED Ltd., Manuf.: Caduceum Ltd., Excl.Distributor: BioLabor Biophysic Ltd.
www.biolabor-med.com



ELECTROMAGNETIC OWN SIGNAL TREATMENT

2012

How often, how many treatments or what kind of treatments can be necessary by EMOST™ in a given disease.

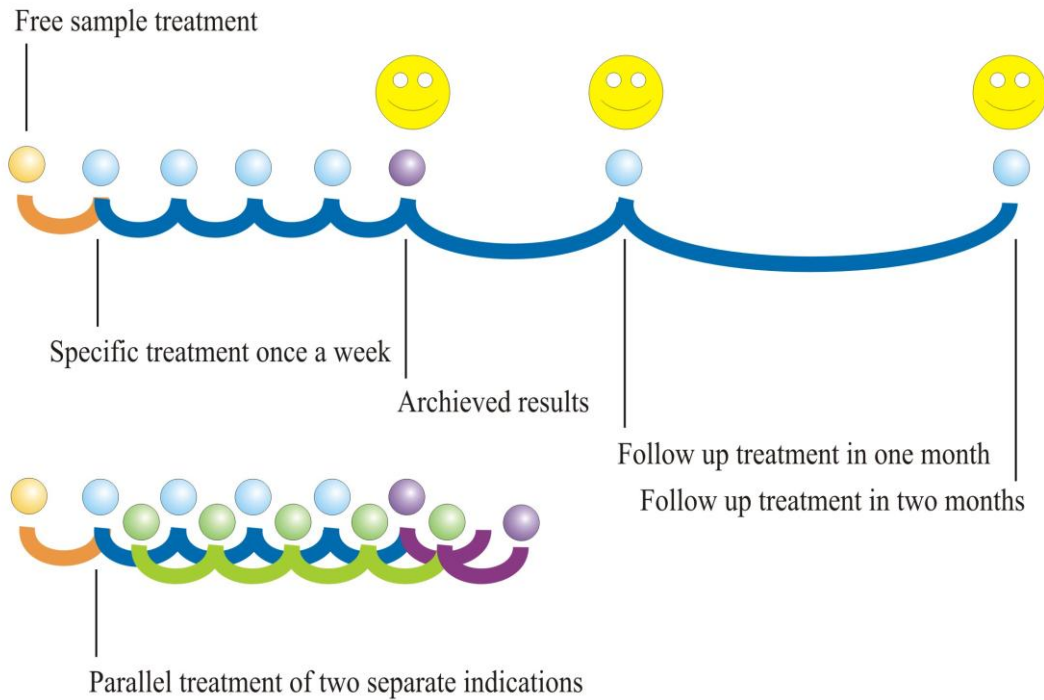

⚠ As the medical intervention is done by the subject's own functional signals, the body records the correction process, and **can later reproduce it on its own** (eh. immune-memory) may **in years**.

⚠ High-Tech and easy to use! The EMOST™ medical device is full self-acting and pre-programmed, just choose a treatment, than the unique device works (after seven years of testing and developing) automatically.

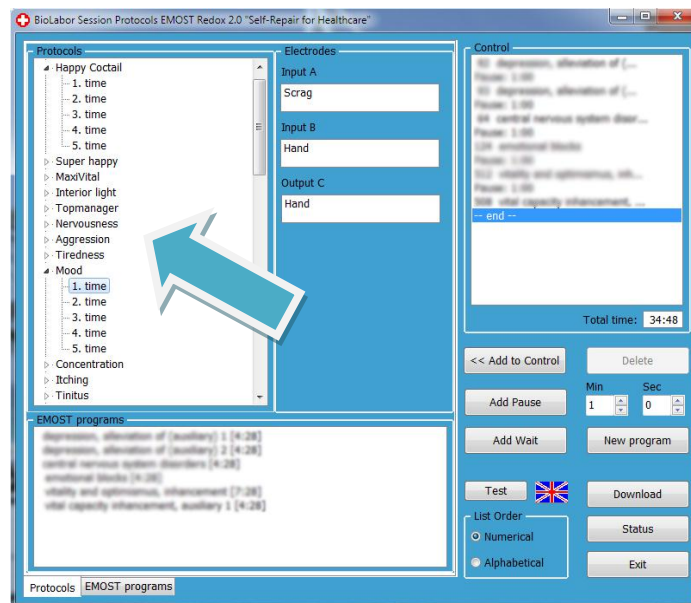

ELECTROMAGNETIC OWN SIGNAL TREATMENT

2012

BioLabor EMOST[®] effectiveness according to our last years experiences

- a) regular health maintenance in chronic cases
- b) neurovegetative based diseases
- c) neuro-endocrin and immunological diseases
- d) fear, psychic stress related (mental) diseases, depression, lethargy
- e) sleep disorders
- f) central nervous system diseases, concentration, sensitivity etc.
- g) cardiovascular diseases, arhythm
- h) respiratory diseases, asthma
- i) phantom limb pain rehabilitation, amputee rehabilitation
- j) PTSD – Post Traumatic Stress Diseases rehabilitation
- k) allowance of risks in implantation
- l) skeleton and muscular-skeletal disorders
- m) stomach and intestinal diseases, irritable intestine syndrome
- n) skin and subcutaneous tissue disorders
- o) genito-urinary problems
- p) in case of injuries and fractions
- q) in case of allergic diseases on the skin

Other clinical results:

Veins, phlebitis, vascular wall, varix, venectasia (8), wound healing (6), traumatic bone (3), cardiovascular parameters (1,2), spermium activity (10), sclerosis multiplex (15), pains (5,7,14), rheuma, rheumatic pain (7,12,17), osteochondral defects (13) hypertension (9), depression, feeling blue, lethargie, distress, psychiatric diseases (1,16,18,19), cronical tiredness (19), sleeping quality (1), fibromyalgia (11,7), brain alpha activity (1,2,5), opioid system (5), oedema, collagen (4).

- 1) Cvetkovic D, Cosic I. Alterations of human electroencephalographic activity caused by multiple extremely low frequency magnetic field exposures. *Med Biol Eng Comput.* 2009 Oct;47(10):1063-73.
- 2) Dean Cvetkovic, Qiang Fang and Irena Cosic. Multiple human electrophysiological responses to extremely low frequency pulsed electromagnetic field exposures: a pilot study. *Estonian Journal of Engineering* 2008, 14, 2, 138–153.
- 3) Abdelrahim A, Hassanein HR, Dahaba M. Effect of pulsed electromagnetic field on healing of mandibular fracture: a preliminary clinical study. *J Oral Maxillofac Surg.* 2011 69(6):1708-17.
- 4) Uzunca K, Birtane M, Taştekin N. Effectiveness of pulsed electromagnetic field therapy in lateral epicondylitis. *Clin Rheumatol.* 2007 26(1):69-74.
- 5) Ghione S, Seppia CD, Mezzasalma L, Bonfiglio L. Effects of 50 Hz electromagnetic fields on electroencephalographic alpha activity, dental pain threshold and cardiovascular parameters in humans. *Neurosci Lett.* 2005 382(1-2):112-7.
- 6) Rohde C, Chiang A, Adipoju O, Casper D, Pilla AA. Effects of pulsed electromagnetic fields on interleukin-1 beta and postoperative pain: a double-blind, placebo-controlled, pilot study in breast reduction patients. *Plast Reconstr Surg.* 2010 125(6):1620-9.
- 7) Shupak NM, McKay JC, Nielson WR, Rollman GB, Prato FS, Thomas AW. Exposure to a specific pulsed low-frequency magnetic field: a double-blind placebo-controlled study of effects on pain ratings in rheumatoid arthritis and fibromyalgia patients. *Pain Res Manag.* 2006 11(2):85-90.

ELECTROMAGNETIC OWN SIGNAL TREATMENT

2012

- 8) Cañedo-Dorantes L, García-Cantú R, Barrera R, Méndez-Ramírez I, Navarro VH, Serrano G. Healing of chronic arterial and venous leg ulcers through systemic effects of electromagnetic fields. *Arch Med Res.* 2002 33(3):281-9.
- 9) Nishimura T, Tada H, Guo X, Murayama T, Teramukai S, Okano H, Yamada J, Mohri K, Fukushima MA 1- μ T extremely low-frequency electromagnetic field vs. sham control for mild-to-moderate hypertension: a double-blind, randomized study. *Hypertens Res.* 2011 Mar;34(3):372-7.
- 10) Iorio R, Delle Monache S, Bennato F, Di Bartolomeo C, Scrimaglio R, Cinque B, Colonna RC. Involvement of mitochondrial activity in mediating ELF-EMF stimulatory effect on human sperm motility. *Bioelectromagnetics.* 2011 32(1):15-27.
- 11) Sutbeyaz ST, Sezer N, Koseoglu F, Kibar S. Low-frequency pulsed electromagnetic field therapy in fibromyalgia: a randomized, double-blind, sham-controlled clinical study. *Clin J Pain.* 2009 25(8):722-8.
- 12) Duygu Geler Külçü, Gülçin Gülşen, Elif Çiğdem Altunok. Short-Term Efficacy of Pulsed Electromagnetic Field Therapy on Pain and Functional Level in Knee Osteoarthritis: A Randomized Controlled Study. *Turk J Rheumatol* 2009; 24: 144-8.
- 13) van Bergen CJ, Blankevoort L, de Haan RJ, Sierevelt IN, Meuffels DE, d'Hooghe PR, Krips R, van Damme G, van Dijk CN. Pulsed electromagnetic fields after arthroscopic treatment for osteochondral defects of the talus: double-blind randomized controlled multicenter trial. *BMC Musculoskelet Disord.* 2009 10;10:83.
- 14) Weintraub MI, Cole SP. Pulsed magnetic field therapy in refractory neuropathic pain secondary to peripheral neuropathy: electrodiagnostic parameters—pilot study. *Neurorehabil Neural Repair* 2004;18:42–46.
- 15) Sandyk R. Treatment with electromagnetic fields reverses the long-term clinical course of a patient with chronic progressive multiple sclerosis. *Int J Neurosci.* 1997 90(3-4):177-85.
- 16) Baker-Price L, Persinger MA. Intermittent burst-firing weak (1 microTesla) magnetic fields reduce psychometric depression in patients who sustained closed head injuries: a replication and electroencephalographic validation. *Percept Mot Skills.* 2003 Jun;96(3 Pt 1):965-74.
- 17) Trock DH, Bollet AJ, Dyer RH Jr, Fielding LP, Miner WK, Markoll R. A double-blind trial of the clinical effects of pulsed electromagnetic fields in osteoarthritis. *J Rheumatol.* 1993 Mar;20(3):456-60.
- 18) Baker-Price LA, Persinger MA. Weak, but complex pulsed magnetic fields may reduce depression following traumatic brain injury. *Percept Mot Skills.* 1996 Oct;83(2):491-8.
- 19) Tsang EW, Koren SA, Persinger MA. Specific patterns of weak (1 microTesla) transcerebral complex magnetic fields differentially affect depression, fatigue, and confusion in normal volunteers. *Electromagn Biol Med.* 2009;28(4):365-73.



ELECTROMAGNETIC OWN SIGNAL TREATMENT

2012

Some possible effects of low frequency and intensity electromagnetic fields on cellular processes

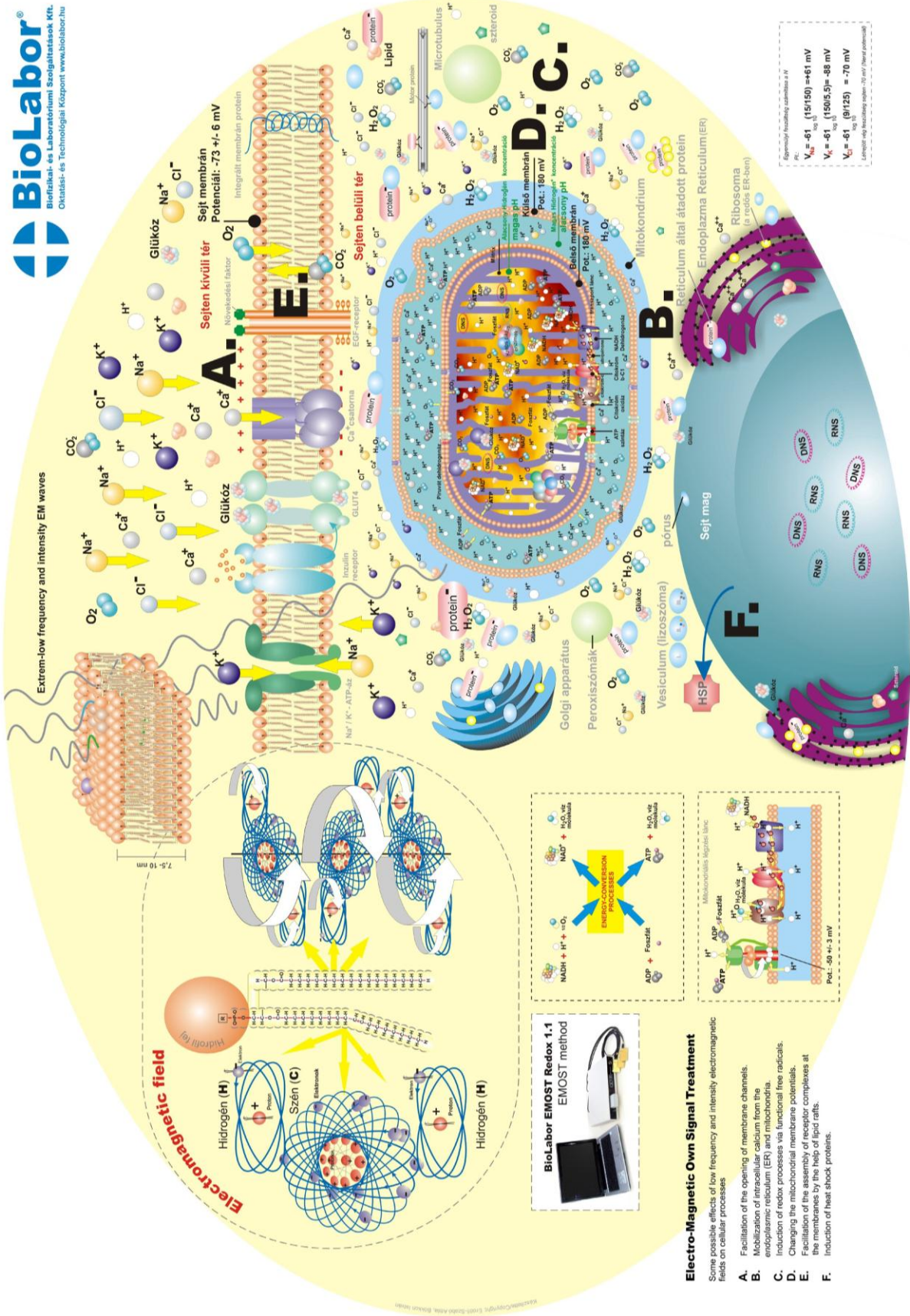

ELECTROMAGNETIC OWN SIGNAL TREATMENT

2012

Mission

4-Future: Quality of sleeping, incontinency, asthmatic and allergic status, mood, hyperactivities



Clinical result: successful treatment of phantom pain (and sleeping, mood) by EMOST



Post traumatic stress treatment by EMOST (original pictures ↓) after flood in Felsözsolca, Hungary



Better concentration, power, rehabilitation, well status after professional sport carriers



EMOST helps better coordination of muscles, psychical stability, vital capacity



ELECTROMAGNETIC OWN SIGNAL TREATMENT

2012

No. 1

Stress related (mental) diseases treatment



Conclusion

The special analog signal processing of the EMOST™ equipment allows much more length of the detected electromagnetic and regenerated electromagnetic signal information than in the digital (signal loss, signal distortion) cases. The EMOST™ method seems to be able to potentiate cellular communication, the control processes and the operation of the biochemical homeostasis in a natural way by reflecting the electric- and electromagnetic impulses coming from the body's own range, all without the use of any artificial electric- and electromagnetic radiation, and the risks thereof.



ELECTROMAGNETIC OWN SIGNAL TREATMENT

2012

EMOST Redox 1.1

USER MANUAL



CE
1979

EMOST Redox 1.1 MEDICAL DEVICE

ELECTROMAGNETIC OWN SIGNAL TREATMENT

2012

1. The EMOST™ units

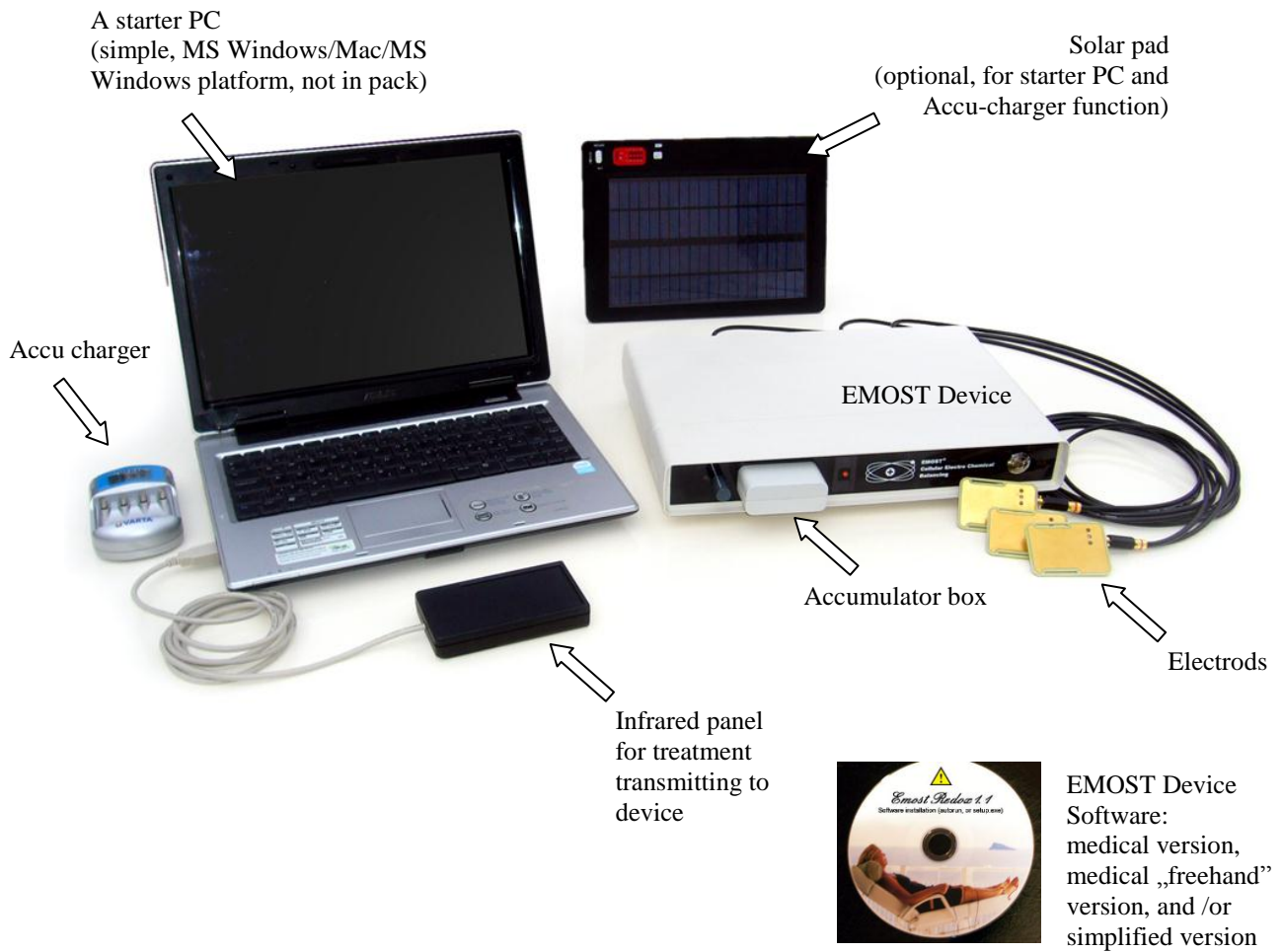

ELECTROMAGNETIC OWN SIGNAL TREATMENT

2012

2. EMOST™ device use

1. Choose a treatment



2. Transmitting to Device

3. The treatment works already



ELECTROMAGNETIC OWN SIGNAL TREATMENT

2012

3. Elements of EMOST™ Device

programming side

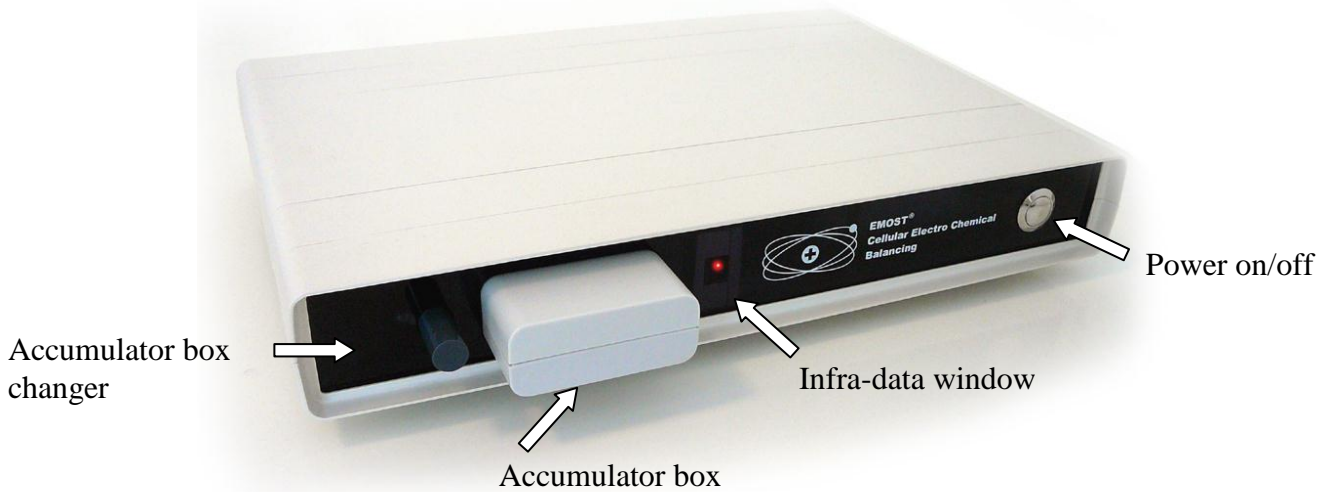

treatment side

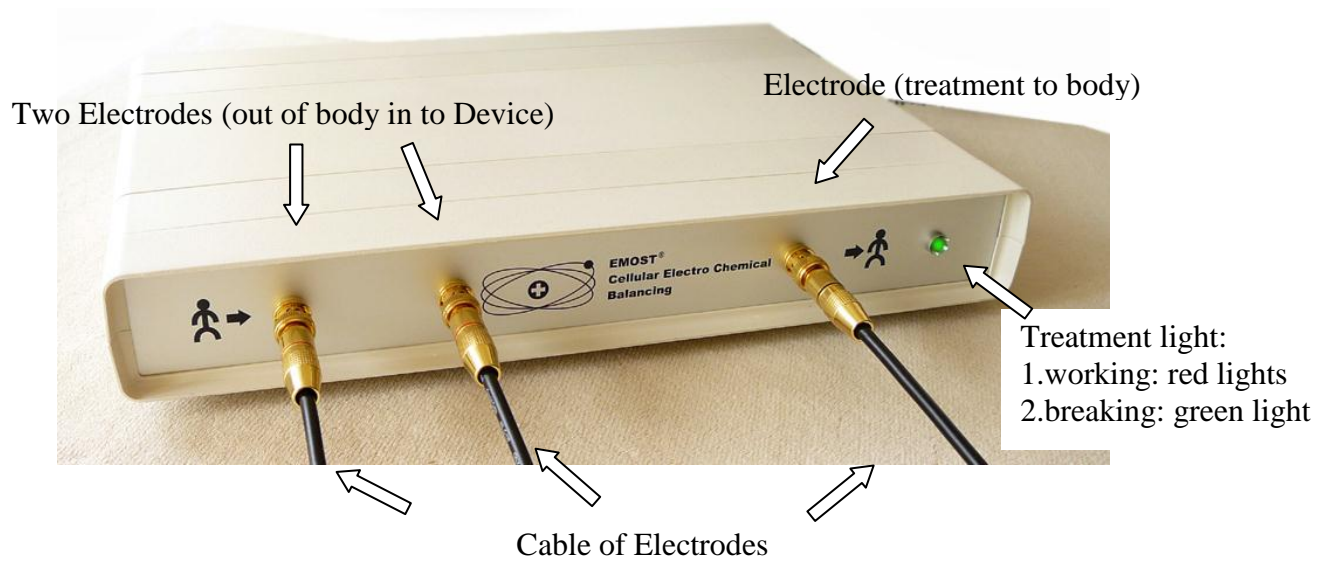

BLUE: treatment to body

REDs: out of body in to Device



ELECTROMAGNETIC OWN SIGNAL TREATMENT

2012

4. Building the extrasense EMOST electrodes



⚠ The material and functionality of electrodes are the same. For easier using: two Red-line cable are for sensing (out of body in to Device), the Black-line cable is treatment to body.

⚠ The extrasense Electrode made of layers. Take care of for good repair! Cleaning every treatment before, with NON-Iodine cleaner (vs.coloring). Controlling the contact of cable: screw the bolts easy to best stability (thermic dilatation)!

Passive side



Active side (non-arsenic gold-plated flat for anti-allergic, and better hygenic status)



ELECTROMAGNETIC OWN SIGNAL TREATMENT

2012

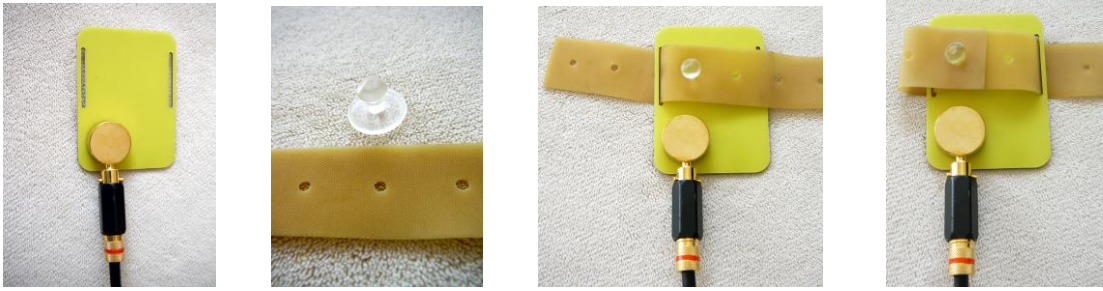

6. EMOST Electrodes on skin

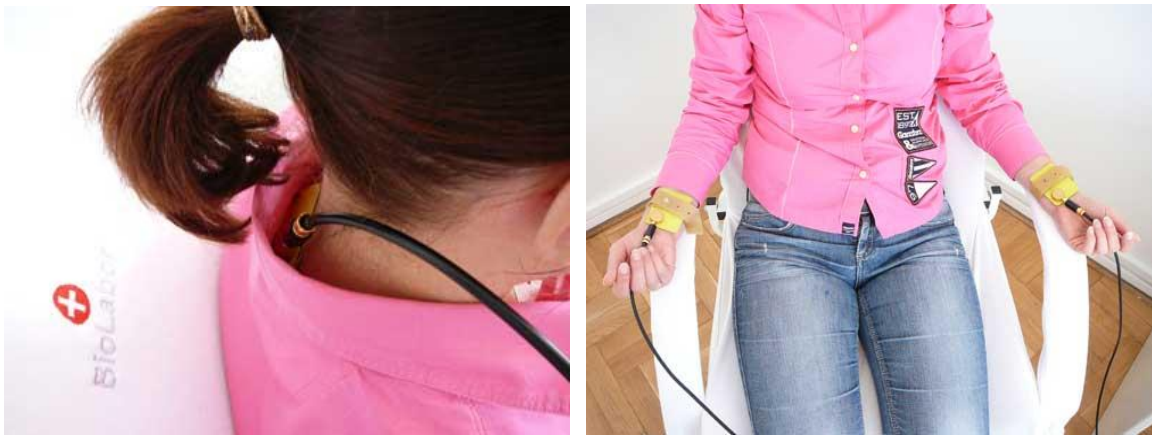

BLUE point: treatment to body

RED points: out of body in to Device

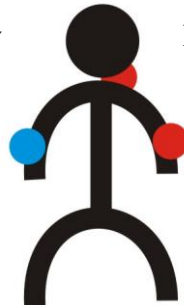

ELECTROMAGNETIC OWN SIGNAL TREATMENT

2012

7. Power of Device, the accumulators



Accumulator box changing:
Push the gray bottom

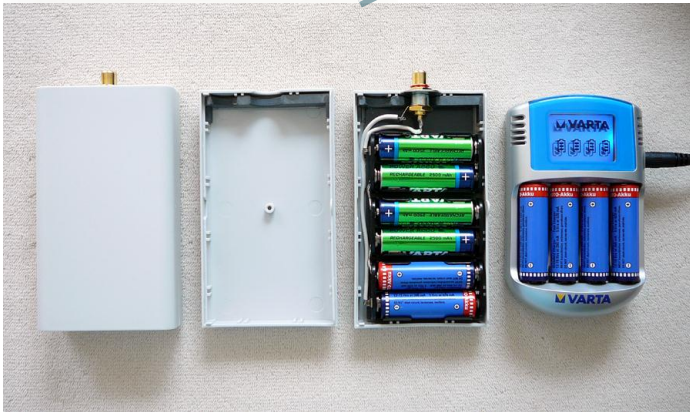

Easy to charge!

6 pieces Rechargeable ACCUMULATORS
(2700 mA)

⚠ Charge with AC/Adapter!



Easy to charge, use the device by free-energy everywhere!

⚠ Charge with Solar panel. (optional)



In extreme situation you can to use by normal alcalic BATTERY too.

⚠ DO NOT CHARGE!

ELECTROMAGNETIC OWN SIGNAL TREATMENT

2012

8. The BioLabor EMOST Software



Setup.exe on CD or Download from internet (medical version, medical „freehand” version, and /or simplified version)



Icon on PC to Start the software

Picture: medical „freehand” software version together with simplified version

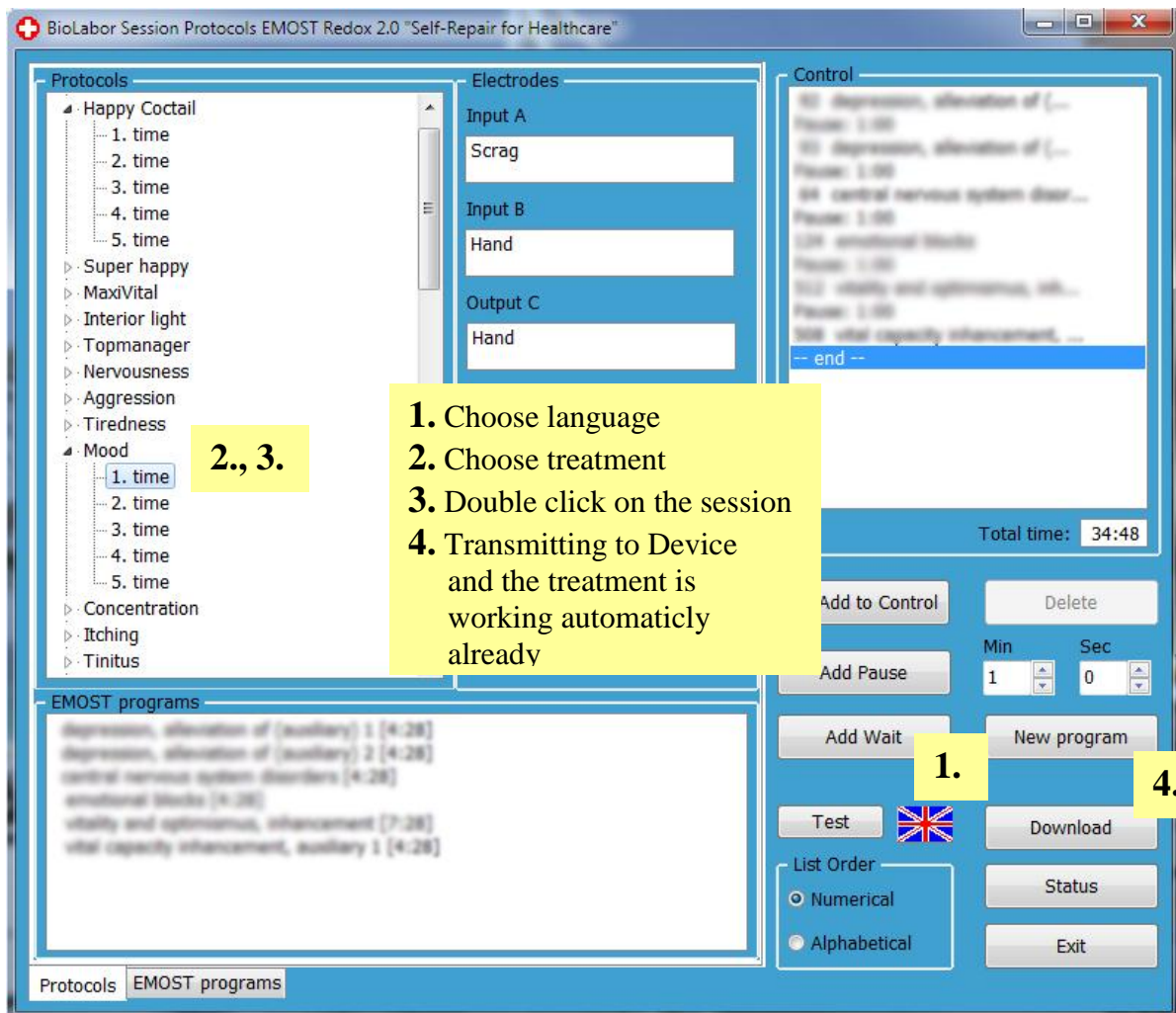

1. Choose language
2. Choose treatment
3. Double click on the session
4. Transmitting to Device and the treatment is working automatically already

1.

4.

ELECTROMAGNETIC OWN SIGNAL TREATMENT

2012

What does affect the result of the different treatments?

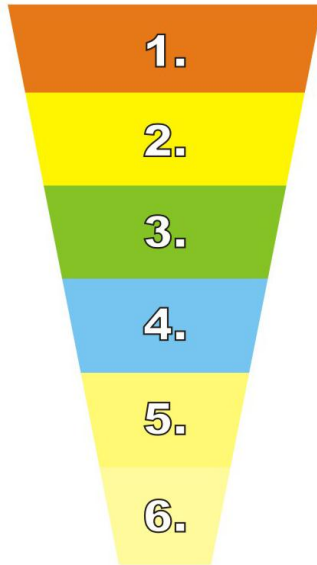

It affects the water consumption, the adaptation-ability of the organism, vitality, that is the capacity and the adaptability. The half hour long treatment is like a lesson in the school, by and by the capacity decrease, that's why the breaks between the classes help. This decrease can happen during the half hour treatment, so we place **one-one second break** between the treatment elements, we can easily turn it on, so the organism can approach, regenerate process the program.

With considering these things, when we compile the given day treatment to the patient, then we should load the program-elements from the Treatment List to the device in the same order, that it is in the chart. This order of importance is important because of another reason that is the psychological and physical state is very affective.

Example: In the case of weather sensitivity we load the 528. program to the device, then the number 73. to the second place, and so on. The supporter program-element that has role, but it's not obligatory comes to the last place.

Weather sensitivity	
528.	weather sensitivity
73.	circulatory problems, cervical and cerebral, auxiliary
344.	pain, occipital headache
492.	vegetative regulation, normalization in case of any kind of vegetative distonia
341.	pain, accompanied by cramps
64.	central nervous system disorders

Range diagram of the treatment effectiveness, more stages, during a 40 minutes treatment: (part of the syllabus)

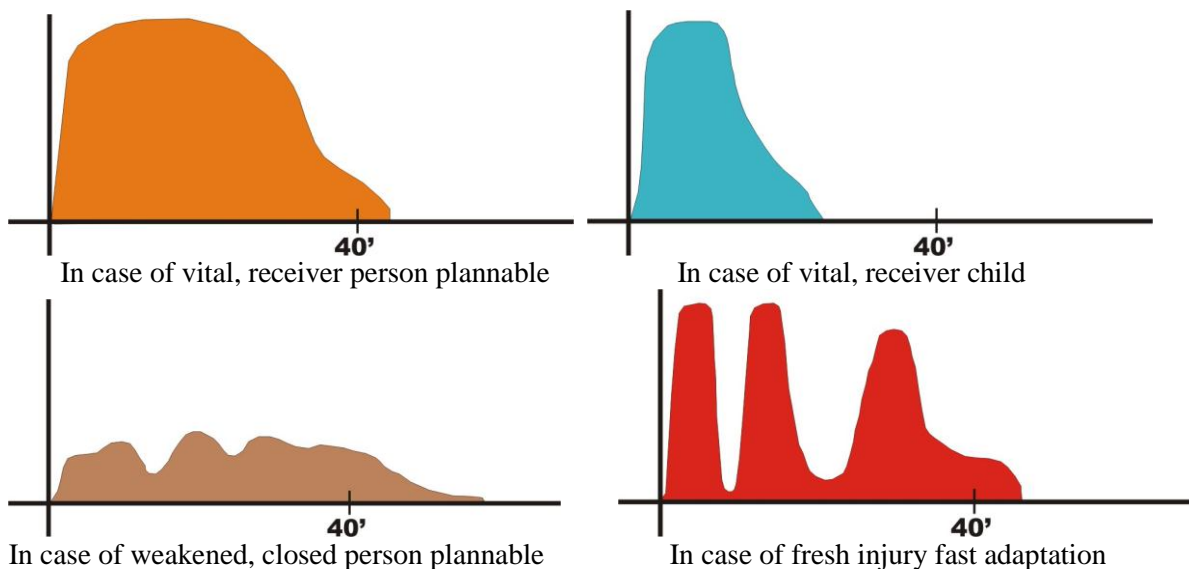

ELECTROMAGNETIC OWN SIGNAL TREATMENT

2012

EMOST[®] preprogrammed, best practices treatment serieses

Aggressiveness	Internal fire - energy control, cellular ATP
Allergies, irritation	Kidney, filtration
Bacterial balance, asepticity	Cosmos - super-sensitivity
Blood components, balance, spleen	Libido increase
Blood glucose, insulin balance	Liver freshening, internal circulation
Blood pressure balance	MaxiVital – stamina
Bone density	Nervous system overload
Bowel pH	Hypo- or Hyperactive thyroid
Cell, apoptosis, periods, contol	Stomach acid, reflux process
Cyst (sist) stop – tissue, regulation	Pancreatic correlations
Concentration - attention, memory	Intestine - mucosal pH
Conception, pregnant	Periosteum
Constipation	Prostate function
Chemical dependence	Restoring - autonomic controllers
Divorce, remission, dependence	Restoring - molecular controllers
Eczema – chemical irritation	Restoring – overall controllers
Eczema – natural based	Sinus, chronic sinusitis
Eczema –psychosomatic	Skin, signal transmitting
Eczema, unknown irritation	Skin, activity of immunity
Eye cataracts - vision clarity	Sleeping, hypo- or hypersomny
Gigant – rhytm of circadian	Spleen operation
Gigant – integrated regulation	Stomach pain - upset stomach
Gigant - vegetative controllers	Super Happy - psyche/body balance
Happy-Cocktail antistress program	Supporting diet
Heart operation balance, pericardium	The correlations of hemorrhoids
Hereditary predisposition, dna-rna	Thyroid operation balance
Hormone SOS - balance of steroid	Top manager, Burn-out syndr.
Humor impaired, lethargy dissolve	Phantom pain
Immunity– antibody-elasticity	Urinary
Influenza SOS - immune balance	Virus recognition

Indications of procedure:

Regular health maintenance in chronic cases, neuro-vegetative based diseases, neuroendocrine and neuro-immunological based diseases, central nervous system based diseases.

We could effectively treat diseases such as:

fear, panic attacks, inhibition, psychic stress related (mental) diseases, epilepsy, depression, lethargy, sleep disorders, cardiovascular diseases, arrhythmia, asthma bronchial, chronic shortness of breath, phantom limb pain and amputee rehabilitation, rehabilitation of Post-Traumatic Stress Diseases, allowance of risks in implantation, chronic stomach cramps, irritable intestine syndrome, cognitive difficulties, bulimia, chronic constipation, incontinency, conception difficulties.

ELECTROMAGNETIC OWN SIGNAL TREATMENT

2012

9. Treatment data transmitting to Device



Direction:

Treatment data transmitting via Infra unit in this direction.

The distance are between units maximum 0,7 m (70 cm).

10. Testing the Device

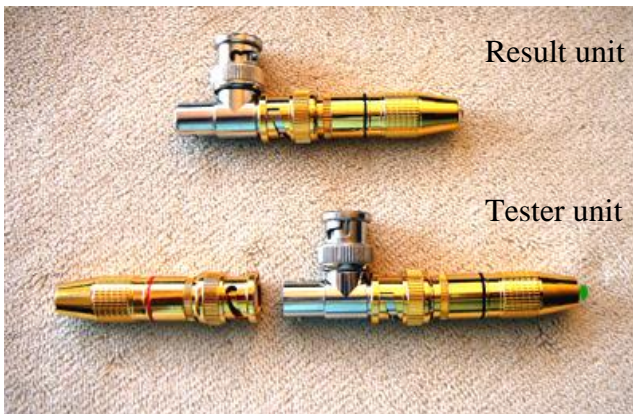

1. Tester unit with green LED light (with mini-accumulator power –include)
2. Result unit with white/yellow light.

⚠ Take the units the Device on, push TEST button on the Software, its testing about 5 minuts.

The Device is working well, when the yellow light is pulsed.



The EMOST Redox 1.1. electro-biostimulation device

ELECTROMAGNETIC OWN SIGNAL TREATMENT

2012

11. Device properties

- a) -works through the surface of the skin,
- b) -temporary application (16/2006. (III. 27.) EüM 1.1.HU),
- c) -based on the principle of providing immediate feedback,
- d) -has an electro-biostimulating effect via natural based electrophysiological process
- e) -based on non-invasive treatment (16/2006. (III. 27.) EüM 1.2.HU),
- f) -extremely low intensity (its functional range is <10mikroTesla, <mV)
- g) -applies electro- electromagnetic impulses (frequency range is 1- 1.000.000 signal/sec),
- h) -internally powered, requires 7,2 V DC (direct current, 6 x 1,2V AA type batteries)
- i) -used by natural based non-linear shaped signals,
- j) -cyclical, dynamic impulse emission,
- k) -automated, pre-programmed, indicated,
- l) -marked **CE 1979** (medical device), directive **93/42/EEC**, Cert. No.: **HU11/6192-SGS**
- m) -codes of competence of health professions (6/2012.(II.14) NEMFI HU): 5704, 5722 physiotherapy/electrophysiotherapy, 6400 general medical care, 0100 general internal medical care, 0903 rehabilitation of neurology, 0500 general paediatrics, 9400 preventive- and public health care, 8046 reflexzone therapy, 8717 complementer electrophysiological care
- n) -fits the IEC-601-1-2 standard from the aspect of the electromagnetic effect, and also fits the IEC complementary standard,
- o) -belongs to the II/A group considering the potential danger in connection with the application
- p) -has extremely low risks in contra-indication (contra-indications: all the general contra-indications referring to physiotherapy, inexplicable diagnosis, individual sensitivity to the specific effect, unexplained shivers etc.),
 - a. likely is free from side effects,
- q) -can be applied independently or in combination with other devices,
- r) -is compatible with other methods,
- s) -simplified control software application does not require thorough anatomic competence or any specific preparedness,
- t) -medical control software application does require thorough anatomic competence and any specific preparedness,
- u) -it can be applied by following the Instruction Manual,
- v) -it can be used for the purpose of remaining healthy, prevention, and medicine.

Contra-indications:

- a) inexplicable diagnosis, unclear acute disease
- b) vomiting, ventral pain,
- c) rapid pulse, vertigo,
- d) catatonic state, fainting,
- e) inability to communicate
- f) personal sensitivity to the specific process
- g) unexplained shivers

Factors influencing the efficiency of the treatments:

- a) dehydration of the body, low fluid
- b) intake
- c) abnormal nutrient deficiency
- d) abnormal constant stress
- e) constant unhealthy environment
- f) constant unhealthy lifestyle

ELECTROMAGNETIC OWN SIGNAL TREATMENT

2012

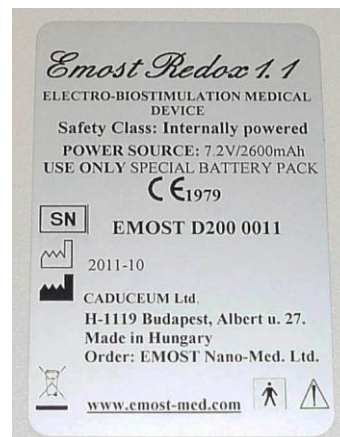

Certificate and tag

12. Datas EMOST Redox 1.1 Medical device

Type:	elektro-biostimulation, medical device
Competence:	biofeedback, electrochemical, neurology
Medical category:	electro-physiology
Range of Signals:	<10 μ T, <milliVolt, 1 Hz – 1 MHz (-3 dB)
Fourier transformations:	to 5 MHz (-14 dB)
Amplifier of signals:	-20 dB +60 dB (steps by 1 dB)
Power of device:	internally powered, 7,2 V / 2300 mAh, with 6 pieces NiMH rechargeable accumulators

Personal computer (not in pack)

Configuration:	20GB HDD, 10 MB Ram, CPU 1,6GHz, MS-Windows or MAC/MS-Windows platform
Power:	Medical type of charger

Software

Types:	medical version, and simplified version
Volume:	3MB
Language:	english, espain, hungarian, russian
Software know-how:	Dr. Attila Erdőfi-Szabó Ph.D.
Method registered in medical science:	Dr. Attila Erdőfi-Szabó Ph.D., 2011
Manufacturer:	Caduceum Ltd.
Order of manufacturing:	EMOST Nano-MED Medical Manuf. Ltd.
Exclusive distributor:	BioLabor Biophysical & Lab's Services Ltd.
Official website:	www.emost-med.com



We are going to have an interview with Dr Attila Erdofi Szabo, the developer and chairman of Biolabor Biophysical and Laboratories Ltd about (Electro-Magnetic-Own-Signal-Treatment) called EMOST, which is a new medical technology. The interview is followed by the Budapest Chamber of Commerce and Industry medical conference interviewer is Laszlo KAROLY

“Our BioLabor company has got several years professional experience and also a kind of conservative approach to life. We have gathered skilled colleagues to organize a team in which people can not only look after the patients and but are sufficiently open to cutting-edge technologies as well.

Our staff and company proprietors works in different areas of healthcare and are outstanding representatives of general practitioners, internists, military doctors, pharmacists, university teachers, scientists. The beauty is that our skilled colleagues are very different but they are capable of a higher-order mission to take their work. Our goal is to set an example about compatibility, dedication and professional service.

How many professionals do work for your company and internationally, how many have got involved in medical researches and developments?

Our team is international, we have more than two hundreds skilled colleagues over the world to look after patients and to provide good services at moderate prices.

Our colleagues regularly attend professional trainings. In addition, there are researchers who continuously collect the latest scientific results from various disciplines. Therefore, we can work similarly as a clinical institution.

Typically, the BioLabor Company participates in about six national and international congresses and conferences every year. We use the gained knowledge to educate the younger generation, in daily practice, and in our examinations. We regularly present lectures to the public about the management of psychological and environmental stress, information about physical-physical and physical-psychological relationships and their importance, as well as about how people can recognise harmful effects.

Mr. Erdőfi, can you please introduce the operating mechanism of EMOST XXI century 's new medical device!

The main aim of the Humans is to perform the process of self-recovery, meaning that your body is able to heal itself. I think we got very close to it.

After more than a decade of research we can say that humans are able to recover control of their own state, similarly, when we are tired from working hard and go to bed at night and in the morning we wake up freshly.

Own bioelectric and bioelectromagnetic signals of our body system can represent the actual biological processes and when these own signals can be re-arranged, the body can recover itself. Our EMOST method uses the detected own bioelectric and bioelectromagnetic signals from subjects' skin, and then the subjects are treated by processed own signals originated from device, which help re-arrange own signals of body system and the body can recover.

The major effect of this special EMOST medical device is achieved through the autonomic nervous system by re-arranges of controlling signal problems. Some unique features of this device are the followings: precision, accuracy, no side effects of treatments, and permanency. Usually it is able to alleviate or cure chronic and slow-healing symptoms by low number of treatments, about 5 treatments to a given disease.

[What kind of official institutions do the EMOST know how medical device have controlled and used by?](#)

The Electro Magnetic Own Signal method has a Hungarian know-how. Our EMOST medical equipment has certificate, CE-1979 mark, according to relevant directive 93/42/ EEC.

Our method has been accepted by NATO Centre of Excellence for Military Medicine, Medical University of Vienna, Hungarian National Police and Provost Duties, Hungarian Military Hospital, Hungarian Army, Hungarian Police Anti-terrorist Unit, Marksman- and Tactical Units Training Department, and EMOST medical equipment was checked by Russian Academy of Science, Ukrainian Academy of Science. In addition, the Hungarian National Institute for Medical Rehabilitation has been using the EMOST method for two years.

[What is the basic principle of EMOST Therapy?](#)

As we mentioned, our body refreshes itself every day: in the evening you go to bed tired after work, and then, you get up in the morning and feel "recovered". How does it happen? We deal with this neuro-vegetative regenerating own signal processes.

Our body can re-arrange/ regenerating itself by detected, processed and back-transmitted electromagnetic signals originated from device.

We use the human body's own signals, what is natural, low intensity bioelectro- and bioelectromagnetic impulses (similarly to ECG and EEG signals) which belong to the person's various biological processes. Under EMOST treatments, there is a continuous interactive interaction between the body and the device.

Our unique signal processing method is able to sense biological events with different signal densities (1-1.000.000 signal/sec, intensity range is between milli- and 10 micro Teslas), and instead of randomly selecting certain moments, it can continually and parallel refine the body's self-controlling and self-regulation processes.

Namely, EMOST (Electromagnetic Own Signal Treatment) device can detect bioelectric and bio electromagnetic signals from patients' skin by special electrodes. (this needs a very sensitive device) We detected some natural electromagnetic signals of body, we keep the original shape of wave's form (this is the unique of the World –presumable). We select, and some own signals we enlarge via Fourier transformation, and some Fourier enlarged natural own signals we make amplification between -20 dB + 60 dB, and we are transmitting back the original and the various signals in to the interactive circle of body on an another point. All signals are non-digitalized natural based analogues wave form. The special analogous process makes it possible that the biophysical information content of detected and back-transmitted electromagnetic signal is much precise and accurate than in digitized methods.

The skin (free nerve endings, receptors) detect and re-sensing the internal signals out of external point, controlling those, adaptation and auto-regulation, and may memorizing those) and the balance control of the electro-chemical processes (modulation of free radicals and antioxidants, redox processes as well as neurotransmission, and potentials/action potentials status) via the electro-chemical processes of the impulses and cellular receptors and free nerve endings. The state-of-the-arts EMOST method helps adjust and regulate directly the basic physiological flows of the body, organs and cells. This is our know-how too.

The EMOST method can potentiate the cellular metabolism, detection and immune processes in a natural way through the electric- and electromagnetic impulses coming from the body's own range (EMOST™ know-how). By doing that it helps the biochemical homeostasis to recover, and helps for the neurovegetative system in signal transmission and signal recognising.

[What kind of diseases were treated effectively with the EMOST therapy according to your last year's experiences?](#)

According to our last year's experiences, EMOST therapy presented effectiveness, among the followings: in regular health maintenance, in chronic cases, neuro-vegetative based diseases, neuro-endocrin and neuro-immunological based diseases, central nervous system based diseases.

[What are the most common treatments that patients look for?](#)

We could effectively treat diseases such as: concentration, sensitivity, hyperactivity, fear, psychic stress related (mental) diseases, depression, lethargy, sleep disorders, cardiovascular diseases, arrhythm extras, respiratory diseases, asthma bronchiale, shortness of breath, phantom limb pain rehabilitation, amputee rehabilitation, rehabilitation of Post Traumatic Stress Diseases, allowance of risks in implantation, stomach and intestinal diseases, chronic stomach cramps, irritable intestine syndrome, haemorrhoid, bulimia, chronic constipate, skin and subcutaneous tissue disorders, genito-urinary problems, incontinency etc., chemical dependency, nicotin, coffein, stimulators, conception failure, neuro-immunological based allergies among them.

How long does one treatment take and how much does this therapy cost?

The EMOST treatments take about 40-60 minutes. One effective EMOST therapy contains about 5 treatments for a given disease that should be repeated every 2-3 years, because the neuro-vegetative memory can repeat these flows.

The therapy consists of 4-5 treatment. The cost of one treatment is depends on the country's living standards and joint decision of franchisor and operator. It is generally 45 to 90 USD.

Which certifications does EMOST device have?

The electro-physiological device has the medical device certification in the European Union. The company is qualified medical device manufacturer and the production is SGS certified. Medical device certificate Number is CE1979/HU-11/6192, EU

When was the EMOST method recognised in medical science?

In December 2011, our old dream came true when the EMOST method and device has been certified/issued as medical device internationally.

Developer was BioLabor Biophysics and Laboratory Services Inc, István Sass was the electric engineer at Caduceum Ltd., EMOST Nano-MED Medical Device Manufacturing and Innovation Ltd., manufacturer Caduceum Ltd., and scientific researches were directed by Dr. István Bókkon Ph.D., Dr. Attila Erdőfi-Szabó, Ph.D., and by chief surgeon, Dr. Attila Till.

What factors do influence the effectiveness of the treatments?

Factors influencing the efficiency of the treatments are: dehydration of the body, low water intake, nutrient deficiency, constant unhealthy environment, constant unhealthy lifestyle

Contra-indications: unclear diagnosis, ventral pain, rapid pulse, vertigo, catatonic state, fainting, inability to communicate, personal sensitivity to the specific process, unexplained shivers.

Who are the strategic partners of BioLabor Hungary?

Our strategic partners are the followings: National Institute for Medical Rehabilitation, Hungarian Army Independent Health Insurance, Independent Armed Forces Trades Union Congress, Hungarian Independent Police Union, National Police and Armed Forces Training Center, Hungarian Civil Servants Union, Union of Hungarian HR's, National Athletic Association, Golden Hearth Foundation of Cardial Health, Some National and Private Clinics of Children (charity), Some National Public Clinics and Rehabilitations Centres, International Tisza Cluster Association (ITCA), European Union Donau Strategy, Ukrainian Transcarpatian Develop Office (Zakarpalya), some discret contract with politics, some discret contract with manager training centres, and HQ of International Bodyguard and Security Services Association (IBSSA)

Who are the most important scientists of your team?

Dr. István Bókkon Ph.D., Chief Scientific Consulting of BioLabor Biophysical- and Laboratories Services Ltd, Budapest, Hungary, Dr. Attila Erdöfi-Szabó Ph.D. biophysicist, EMOST therapy developer, Pro Deo State University, Chairman of BioLabor Biophysical- and Laboratories Services Ltd, Budapest, Hungary, Dr. Attila Till, surgeon, head of department National Institute for Medical Rehabilitation Amputation Department, Budapest, Hungary, Dr. Róbert Balázs, NATO Centre of Excellence for Military Medicine

Where do BioLabor clinics operate in Hungary and in international markets?

We have almost 100 franchise partners in Hungary, and representative medical clinics with earlier version of device in USA, Canada, Spain, Slovakia, Italy, Germany, United Kingdom, Poland, Romania, Ukraine, Columbia, Portugal, Angola.

What kind of national and international congresses and conferences did you attend as a speaker?

The BioLabor Company attends many national and international congresses and conferences every year. Recently we took part in the 8th European Biophysics Congress and International Conference of Preventive Medicine and Public Health, International Conference of Preventive Medicine and Public Health. at Pécs, Hungary, National Family Medicians (Doctors) Congress Rumania, Neurology Congress at Ukrainian National Science Academy.

Patients can use EMOST treatments in our country with benefit of the EU social security support. If you want to purchase this device under Hungarian conditions, in most cases, you get a 45% non-refundable support that is due to the Operational Programme for Economic.

Please tell us about your successes!

We have excellent results in Post Traumatic stresses, sleep quality, fear and panic attacks, chronic depression, brain activities, problems in cooperation, cognitive functions learning ability, psychological damage like nightmare, labour status after damage, natural ability to laugh , problems in coordination, Burn-out therapy, better stress management, chronic stomach ache, chronic haemmorroid, ability of conception, embryo preserve, ability of pregnancy, natural libido and harmonic feeling, menstruation problem in professional sports, better professional sport activities higher capacity with Olympic world champion and international gold medals.

I would like to emphasize that all of our statements can be checked while given treatments we are ready to answer related to medical questions or offer tests for patients if anybody is happy to take our kind invitation.

We have got hundreds of feedbacks from satisfied patients after EMOST treatments with rheumatics and rheumatic pain, wound healing, traumatic bone injury, chronic tiredness, depression, cardiovascular parameters, allergy among them...

In case of children, the treatments were especially effective due to the large plasticity of the central and the autonomic nervous system in young patients. It was particularly gratifying when we could report about the effectiveness of EMOST treatments in reduction of phantom limb pain as well as improvement of the quality of sleeping and mood under clinical circumstances. It was also gratifying when we performed the successful application of EMOST treatments for stress management of humans under catastrophic conditions.

[What are the main differences if you compare the EMOST method with other therapies?](#)

The most important differences are:

The EMOST method uses patients' own bioelectromagnetic signals, don't use any artificial electric- and electromagnetic signals, this natural based signals can guarantee extreme low risks, because works in natural range of body. We use the autonomous and central nervous system, and helps in action potentials, and bio-electro-chemical balance. Furthermore the method principle is the body's non-defense mechanism.

[Sorry for interrupting you, What methods are used for the body's defense mechanisms?](#)

For example, artificial electric and electromagnetic stimuli can induce locally load to the tissue, next tissue increases the body's circulation to compensate locally stimuli. Sometimes, for example, use visible light, laser, or the energy intake to elicit local warming that also can induce locally load, so the body also increases circulation to compensate stimuli and to avoid tissue destruction. Otherwise, vaccinations, and some like stimulant also build defensive mechanism.

[Very interesting, are there any other differences?](#)

Many people forget that the body is organized by about 70,000 billion cells, and also that the body has to adapt continuously to internal and external world, so the information flow is continuous in the body.

The artificial signal forms, the artificial electric- and electromagnetic stimuli do not contain natural information originated from our body. These are only switched on-off energie, with information-less stimuli.

Own signal treatment procedure is completely different. Own signals include some information from emotions, through in the nervous system, muscle activity or from any element of central nervous system and parasympathic- and symphatic balance and coordination. The electroencephalogram (EEG) brain activity, and the electrocardiogram (ECG) of cardiac function include all details of information, so, these are typically own signals, which are originated from the subject, and they are

not only continuous variable, but also are unique. Freehand writing has much natural and unique information content but information in a digital computer is template. As you see, there is essential differences between own signals and artificial signals. We only deal with own signals of the body for more than a decade, no with artificial templates. The body itself restores itself with EMOST processed own signals similarly as sleep can refresh us.

[Do you have cooperation with International Insurance company in Hungary ?](#)

Yes we work together with big international health insurance companies called by AXA, AEGON. We work closely with seven the biggest self-managed health funds with successes.

[Please tell us about BioLabor's charity work!](#)

In disaster situations our colleagues strive to help the victims. We try to come first, and we give physical and psychological help to victims and emergency rescuers and His commanders in harder situation.

The charity of our social responsibility is to treat disadvantaged, seriously ill children for free.

[Why and when were you inaugurated as the Knight of Malta?](#)

In 2010, I received this honour for my medical science results and humanitarian activity in pediatric.

[Dr. Erdőfi, Please tell us about your company's connection with National Military Hospital and Hungarian Army!](#)

We have got excellent connection with National Military Hospital and Hungarian Army. Since 2009, we have been serving the Hungarian Army's independent health insurance for the veterans and active staff in service as soldiers, prison guard, police and special weapons and tactics team. We have also been serving our Hungarian UN soldiers after missions in PTSD Post Traumatic Stress Diseases to accept of war tragic events. Some cases we treat amputee veterans for rehabilitation and phantom limb pain healing as well. We have done scientific publications on these treatment results .

[Over government sector, what kind of international military or security agencies do you work together with?](#)

At first I want to mention the IBSSA -International Bodyguard and Security Service Association also with International Auxiliary Police Association.

[Please tell us about BioLabor's international publications!](#)

We are a small company but we publish scientific publication very often:

Bókkon I, Till A, Grass F, Erdőfi-Szabó A (2011) Phantom pain reduction by electromagnetic treatment. **Electromagnetic Biology and Medicine**

Bókkon I., Till A., Erdöfi-Szabó A. (2011) Pilot study, Effects of Electromagnetic-Own-Signal-Treatment on PTS in military actions. In press.

Bókkon I, Till A, Erdöfi-Szabó A (2011) Non-ionizing Electromagnetic-Own-Signal-Treatment. **8th European Biophysics Congress**. 23-27 August, Budapest, Hungary.

Bókkon I, Till A, Erdöfi-Szabó A (2010) Phantom Pain Reduction by Non-ionizing Electromagnetic Treatment. **International Conference of Preventive Medicine and Public Health**. 19-20 Nov. Pécs, Hungary.

Bókkon I, Till A, Erdöfi-Szabó A (2010) Phantom Pain Reduction by Non-ionizing Electromagnetic Treatment. **Nature Precedings** 10.1038/npre.2010.4989.1

Bókkon I, Till A, Erdöfi-Szabó A (2010) Phantom Pain Reduction by Non-ionizing Electromagnetic Treatment. **Hungarian Epidemiology** 7/4/Suppl. p:15. Abstract

Bókkon I., Till A., Erdöfi-Szabó A. (2011) Effect of Electromagnetic-Own-Signal-Treatment on electrocardiogram and the concentration of urea, cholesterol, albumin, cortisol, creatin, TSH, CRP in serum. Under process.

We are looking for nationwide (clinics, hospitals, medical business enterprises) and stronger franchise country distributors partners.

Dr. ERDOFI, thank you very much for the interview!

Thank you Mr KAROLY!

www.biolabor-med.com

The EMOST[®] process
transmitting the natural based extrem-low intensity analogue signals back in natural range

Transmitting back totality of signals (may versions of potentials)

Detection of natural bioelectric and bioelectromagnetic signals

Used bands of detected signals (may periods of potentials)

1. 1-10 signal/sec
2. 10-100 signal/sec
3. 100-1000 signal/sec
4. 1000-10000 signal/sec
5. 10000-100000 signal/sec
6. 100000-1000000 signal/sec

Indicatio:
combinations of signal-bands, variations of amplification and extension of variations

1. Band-pass
2. Amplification
-20 dB, 60 dB
3. Expansion, and extension of variations
Fourier transform
-14 dB to 5 MHz
0,1 sec. - 102 sec

CE 1979 MEDICAL DEVICE

Developer/owner: EMOST Nano-MED Ltd., Manuf.: Caduceum Ltd., Excl.Distributor: BioLabor Biophysic Ltd.
www.biolabor-med.com

UNIQUE OF THE WORLD

PRELIMINARY EXPERIMENTS:

Single EMOST treatment effect on electrocardiogram and the serum concentration of urea, albumin, cortisol, chloride, CPK, TSH, and CRP



UNDER REVIEW

We performed some preliminary experiments on twelve members of our BioLabor regarding the effectiveness of single EMOST treatment on some serum parameters and electrocardiogram (ECG). ECG results did not show statistic significant improvement after single EMOST treatment. In contrast, some serum factor such as uric acid, albumin, cortisol, chloride, Creatine phosphokinase (CPK), Thyroid stimulating hormone (TSH), C-reactive protein (CRP) indicated some remarkable changes following one treatment.

Cortisol, TSH, CRP, and CPK serum concentrations were reduced in the most of us. The albumin concentration usually showed a slight decrease and the uric acid concentration increased in almost all cases. Chloride level of serum showed a slight increase in almost every case. Of course, these few preface experiments have no great importance, but indicate EMOST treatment may reduce stress factors and affect on the redox/free radical processes as numerous studies reported regarding to the effect of low-frequency and intensity electromagnetic fields.

For example, cortisol levels were decreased in most of the members of our BioLabor after one EMOST treatment. Cortisol is a (glucocorticoid) steroid hormone that produced by the adrenal cortex in response to stress (Inslicht et al., 2011). Its major functions are, among them, to increase blood sugar through gluconeogenesis and suppress the immune system, but recent studies revealed that glucocorticoids (cortisol) have both stimulatory and suppressive effects on immune responses that are dependent on the GC concentration (Yeager et al., 2008).

Uric acid concentration increased in almost all cases after single EMOST treatment. However, uric acid is strong reducing agents (electron donors) and potent antioxidants (Warning, 2002). In humans, about the half the antioxidant ability of blood plasma comes from uric acid (Maxwell et al., 1997).

Chloride level also showed a slight increase in almost every case. Chloride is a prominent negatively charged ion in the blood, where it represents about 70% of the body's total negative ion content. However, chloride level has essential role of blood pH value that can influence pH-dependent redox/free radical processes. It seems that EMOST treatments may transiently potentiate functional redox processes.

However, we have started a large-scale, controlled testing of EMOST treatments (with forty subjects and with sham exposed controls) regarding its effectiveness on serum parameters and electrocardiogram. We hope that we can report the results in the near future.

Results:

		OE1-A	OE1-B	OE2-A	OE2-B	OE3-A	OE3-B	OE4-A	OE4-B	OE5-A	OE5-B	OE6-A	OE6-B	OE8-A	OE8-B	OE9-A	OE9-B	OE10-A	OE10-B	OE11-A	OE11-B	OE12-A	OE12-B
mmol/l	Chlor	106,0	113,0	109,0	114,0	107,0	110,0	108,0	110,0	110,0	110,0	111,0	111,0	106,0	109,0	110,0	111,0	111,0	112,0	108,0	110,0	109,0	111,0
g/l	Albumin	43,5	41,0	42,0	37,0	40,0	38,0	45,0	44,0	42,0	36,0	46,0	44,0	39,0	42,0	36,0	43,0	43,0	40,0	46,0	44,0	46,0	45,0
U/L	CK	163,0	158,0	149,0	133,0	71,0	77,0	170,0	148,0	216,0	185,0	197,0	188,0	114,0	207,0	127,0	197,0	219,0	169,0	270,0	163,0	230,0	180,0
mg/l	CRP	3,8	3,7	3,3	3,0	7,0	7,0	2,8	2,6	3,4	3,3	1,3	1,2	4,6	2,5	5,0	2,4	2,5	2,5	2,5	2,3	2,5	2,6
umol/l	Uric acid	434,0	446,0	296,0	285,0	239,0	238,0	156,0	164,0	246,0	246,0	253,0	256,0	309,0	303,0	305,0	364,0	210,0	323,0	228,0	350,0	439,0	357,0
mIU/l	TSH	3,6	2,6	1,4	1,1	2,0	1,6	2,2	1,9	2,2	1,9	1,9	2,0	6,3	6,1	8,6	8,1	1,3	0,9	1,5	1,2	2,4	2,2
nmol/l	Cortisol	381,0	276,0	221,0	141,0	123,0	128,0	215,0	159,0	164,0	120,0	170,0	182,0	333,0	261,0	293,0	208,0	628,0	271,0	215,0	319,0	295,0	316,0



Changing in Creatinin

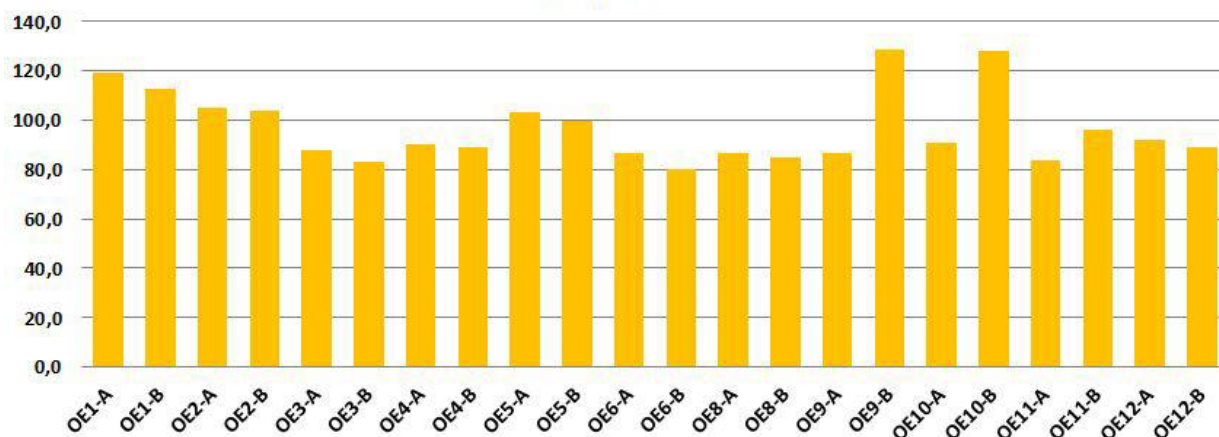

Changing in Chloride

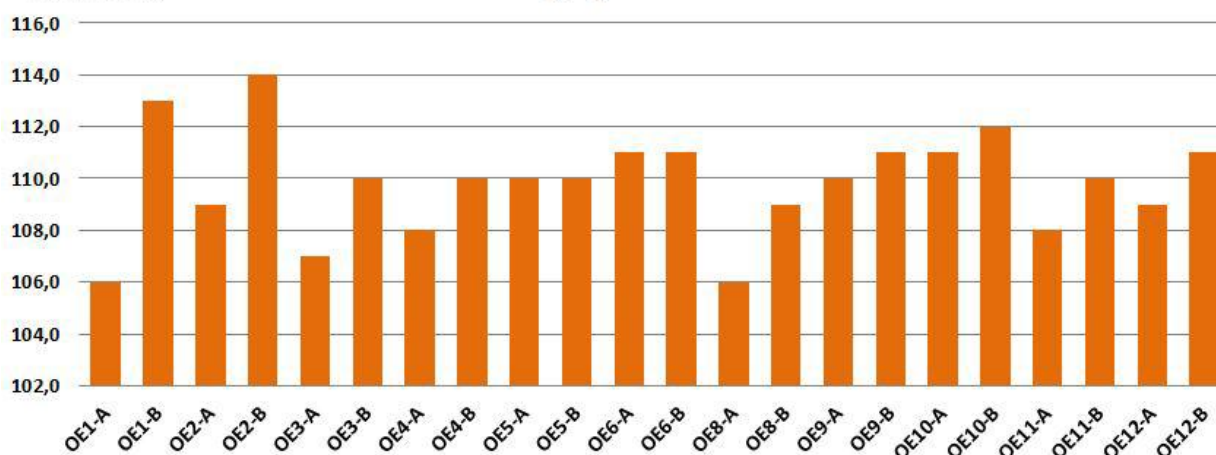

Changing in Albumin

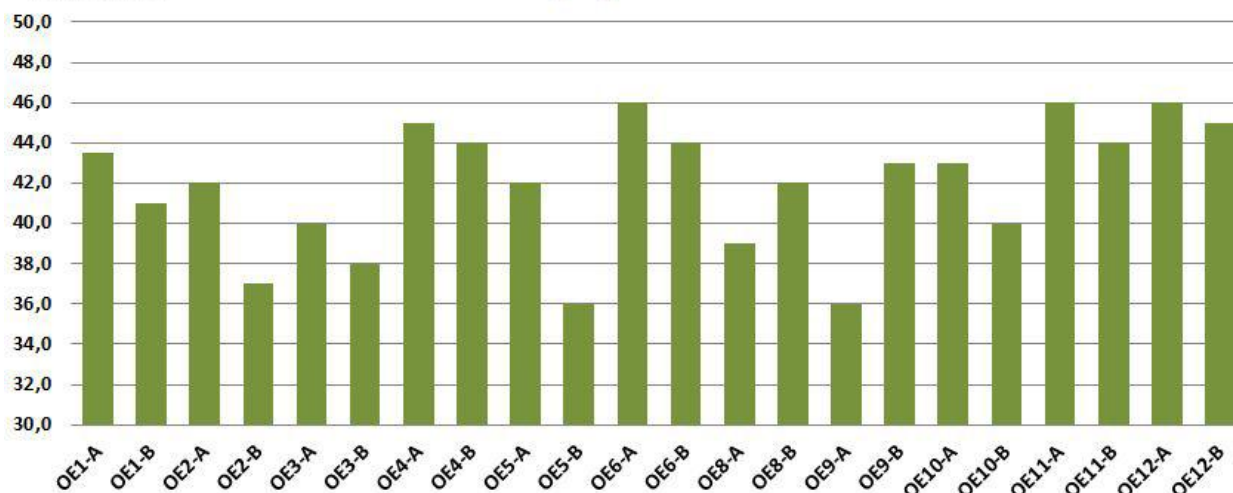

Changing in CK

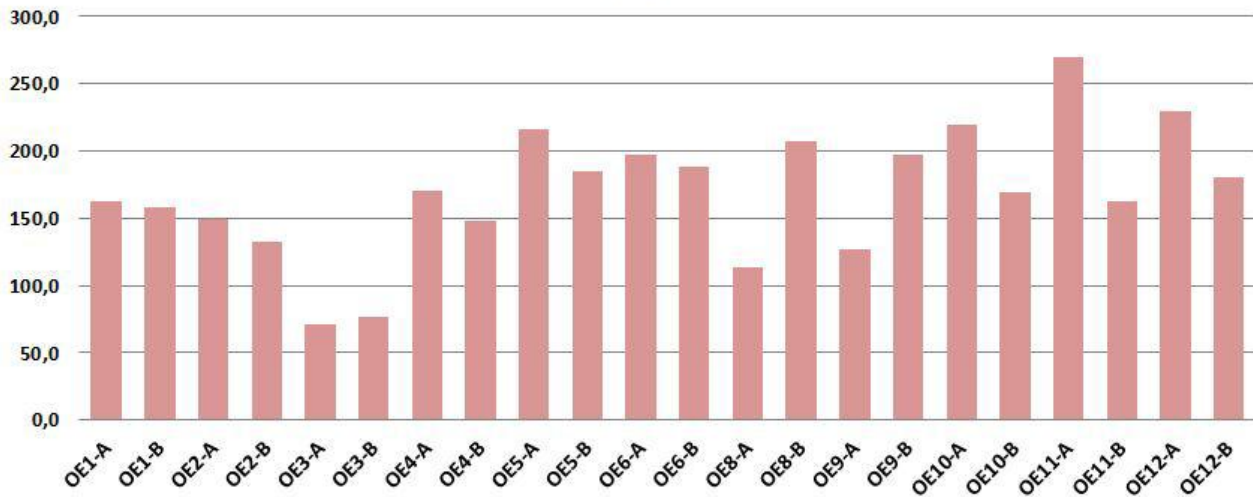

Changing in CRP

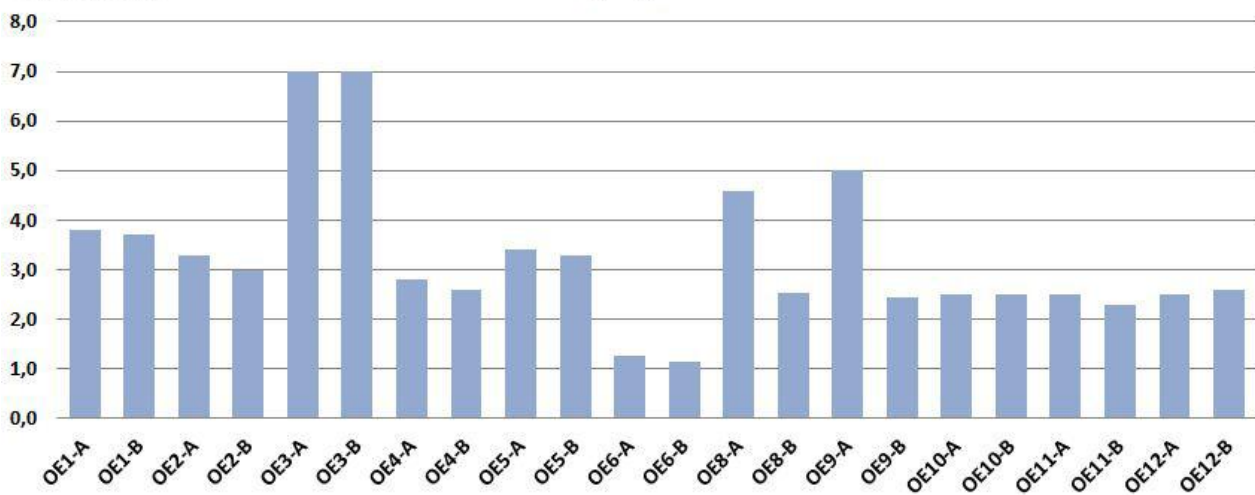

Changing in Uric Acid

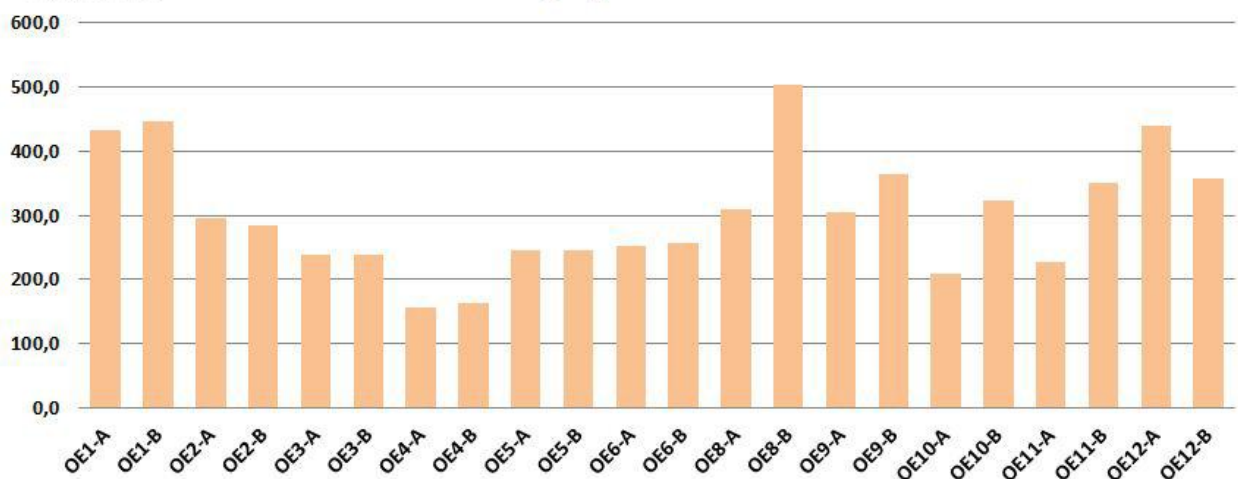

Changing in TSH

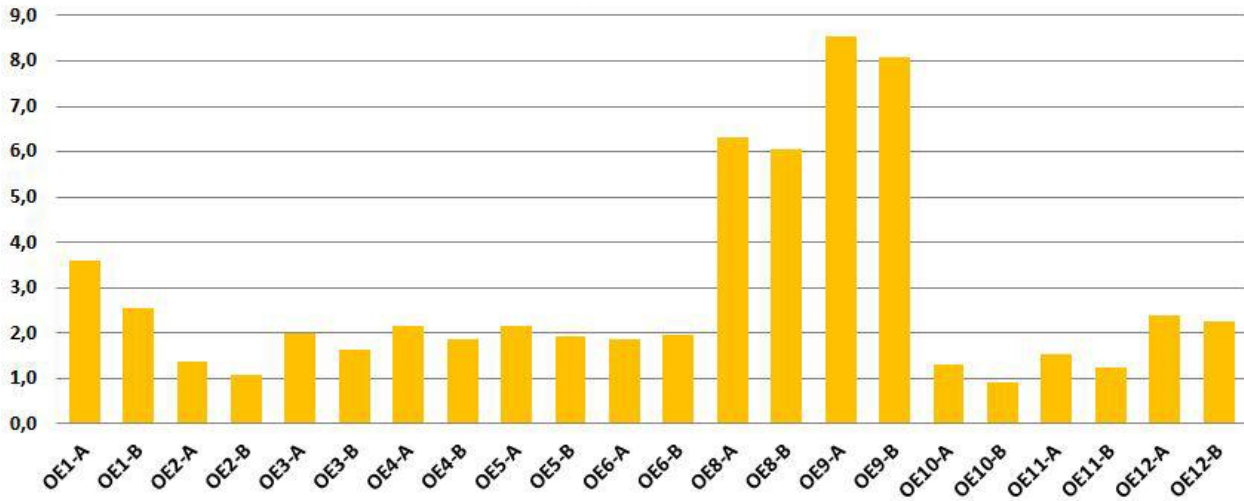

Changing in Cortisol

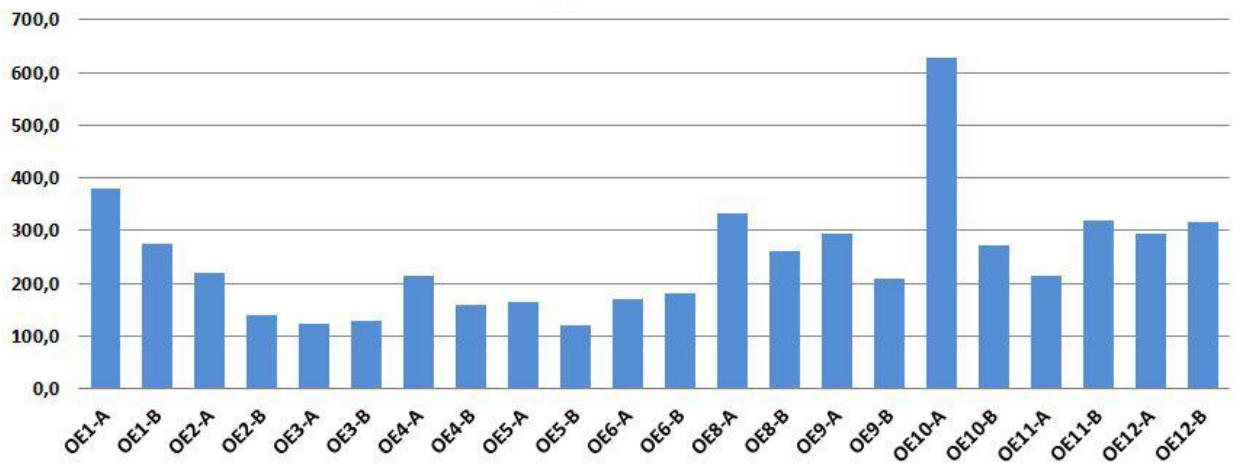

István Bókkon Ph.D.
Attila Erdőfi-Szabó Ph.D
Dr., Sci-Med. Attila Till MD.

EMOST™
biolabor-med.com

Successful new treatment for phantom pain reduction of amputated

The amputation of a limb is generally followed by a sensation that the de afferent body part is still present. The phantom pain aftereffect occurs in 50-80% of the patients who have undergone this type of surgery, and the most frequently reported types of pain include burning, tingling, and cramping. Phantom pain generally resolves without treatment, except in cases in which chronic phantom pain develops. Although various treatments have been presented for chronic phantom pain, there is little proof supporting the benefits of pharmacological treatments, surgery or interventional techniques, electrical nerve stimulation, psychological therapies, etc. However, Hungarian researchers (BioLabor EMOST Research Group) managed to reduce the chronic phantom limb pain by Electromagnetic-Own-Signal-Treatment (EMOST) method under clinical circumstances. The EMOST method may present a breakthrough in the treatment of patients who undergo a major amputation due to vasoconstriction or diabetes or for amputated military veterans in the world.



There is increasing evidence that both peripheral and central neural mechanisms are involved in phantom pain, but the pathophysiological mechanisms of phantom pain remain unknown. According to Hungarian researchers (Dr. Erdőfi-Szabó, Dr. Bókkon, Dr. Till), the nerve impulse conduction could rewrite the body-memory if the nervous system would be able to rewrite the actual pain and feeling patterns by new neutral nerve stimuli. However, in the absence of limb is hardly possible rewrite actual pain and feeling patterns via local/peripheral stimulation. The Hungarian research group has managed to develop a new Own Signal Treatment (EMOST) that induces a self-rechecking of nervous system and can overwrite patterns of phantom pain sensation by neutral stimuli.

In 2010, the EMOST method was examined under clinical conditions in the National Institute for Medical Rehabilitation (OORI). During and after the patients had completed the six EMOST treatments, they did not receive any additional treatments related to the reduction or elimination of phantom limb pain. The reduction of phantom limb pain by EMOST was statistically significant as compared to the controls. After the patients had completed the six EMOST treatments, five of 10 treated patients reported about 50 percent reduction of their pain frequency and intensity. In two of 10 treated patients phantom pain frequency and intensity are decreased with 25 percent, and three of 10 treated patients experienced almost elimination of their phantom pain.

However, the EMOST treatments not only significantly reduced phantom pain of amputated, but also revealed additional benefits at most of the patients after EMOST expositions, such as improvement of their sleep and mood quality. These results were published in international scientific journals as Electromagnetic Biology and Medicine, European Biophysics Journal and Nature Precedings and were presented as a new successful method for the professional audience in congresses as International Epidemiology Congress and European Biophysics Congress.



To assess the long-term effect of EMOST on phantom pain reduction, treated amputated patients were visited after one year of clinical trials. In the cases of treated amputated patients there were no other re-amputations (that unfortunately are very common and frightful in amputated patients with diabetes and vasoconstriction due to interrupt of normal venous and arterial networks) compared to control group. In the last 2 years the OORI amputation department continuously used the EMOST treatments to amputated patients. Their experiences indicate that the EMOST treatments improved wound healing with about 50% after amputations, reduced the frequency of complications and re-amputations as well as improved sleep and mood quality (i.e. reduced stress levels), reported Dr. Attila Till's chief physician at department of amputation.



Since, currently, there is no known effective method to reduce chronic phantom pain; the EMOST can offer new opportunities in the future for the rehabilitation of amputees worldwide.

EMOST application related to possible causes of amputation:

- Cardiovascular diseases
- Consequences of diabetes
- Transport (and other) accidents
- Injuries in natural disasters
- Injuries under military missions
- Tactical civilian injuries

Scientific publications about EMOST:



Source: Dr. Erdőfi-Szabó Attila

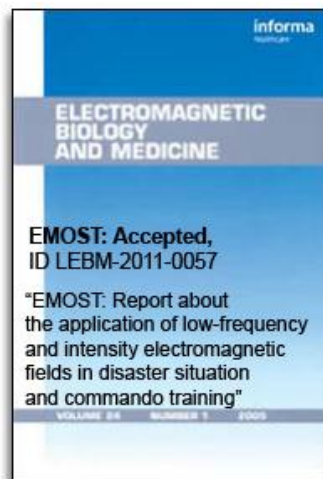

**EMOST: Report about the application of low-frequency and intensity
electromagnetic fields in disaster situation and commando training**
2012 In press DOI: 10.3109/15368378.2012.681823

**^{1*}István Bókkon, ²Attila Erdöfi-Szabó, ³Attila Till, ⁴Róbert Balázs, ⁵Zoltán Sárosi,
⁶Zoltán László Szabó, ⁷Gábor Kolonics, ⁸George Popper**

1 Chief Scientific Consulting of BioLabor Biophysical- and Laboratories Services Ltd,
Budapest, Hungary

2 Pro Deo State University, Chairman of BioLabor Biophysical- and Laboratories Services
Ltd, Budapest, Hungary

3 National Institute for Medical Rehabilitation, Budapest, Hungary

4 NATO Centre of Excellence for Military Medicine, Lessons Learned Branch Acting Branch
Chief, Budapest, Hungary

5 Ret. Police Lieutenant-Colonel, Founder member of Hungarian Police Antiterror Unit,
Branch Chief of Training Master Trainer of Special Units, Budapest, Hungary

6 Ret. Police Lieutenant-Colonel, Hungarian National Police and Provost Duties, Armed
Marshalls Training Center (ORFK-KK) Marksman- and Tactical Units Training Department
Chief, Budapest, Hungary

7 Hungarian Military Hospital, Assistant-head of Ambulance Department, Budapest,
Hungary; Multinational Forces and Observers Sinai Mission-surgeon (from 2000 to 2001);
NATO Skopje HQ surgeon (2003)
kolonicsg@yahoo.com

8 President of International Bodyguard and Security Services Association, Executive
President and Professor of International Budo Academy, Budapest, Hungary

Running title: **Electromagnetic treatment in disaster and commando training**

***Corresponding author: István Bókkon**

Corresponding author's Email: bokkoni@yahoo.com

Corresponding author's Address: H-1238 Budapest, Lang E. 68. Hungary

Corresponding author's Phone: +36 20 570 6296

Corresponding author's Fax: + 36 1 217-091

Abstract

Recently, we published our results (Bókkon et al. 2011 Electromagn Biol Med.) regarding the effectiveness of the EMOST (Electro-Magnetic-Own-Signal-Treatment) method for the reduction of phantom limb pain under clinical circumstances. However, EMOST treatments not only significantly reduced phantom pain, but that most of the patients also reported about additional benefits such as improvement of their sleep and mood quality after treatments. Here we report some unusual applications of EMOST method under special situations. That is, we report about our effective EMOST treatments of humans under catastrophic conditions and commando training course. This article points out that it is reasonable to apply biophysical electromagnetic management under unique circumstances. We also report some preliminary experiments on twelve members of our BioLabor regarding the effectiveness of single EMOST treatment on some serum parameters and electrocardiogram.

Keywords: EMOST treatments, Catastrophic conditions, Commando training

Introduction

To the best of our knowledge, the treatment of humans by low-frequency and intensity electromagnetic fields under special situations has never been reported before. In this article, we report on the application of our EMOST method (Electro-Magnetic-Own-Signal-Treatment) in disaster situation and commando training. The goal of this paper is to demonstrate the non ionizing biophysical electromagnetic management under real-life and unique conditions and not the presentation of clinical or controlled trials.

Health-promoting effects of low-frequency and intensity electromagnetic fields

While the health-promoting outcomes of low-frequency and intensity electromagnetic fields (LFI-EMFs) can be divisive, numerous experiments suggested that LFI-EMFs are able to initiate different healing processes, such as induction of analgesia, acceleration of bone fracture processes and wound healing (re-epithelialization), antiinflammatory effects, decrease of fatigue and depression symptoms, improvement of multiple sclerosis, fibromyalgia, and chronic pulmonary disease, improvement of cardiovascular parameters, improvement of sleep and psychiatric disorders, etc. (Baldi et al., 2007; Barzelai et al., 2009; Mach and Persinger, 2009; Mancuso et al., 2007; Nishimura et al., 2011; Sandyk, 1997; Ghione et al., 2005; Kumar et al., 2005; Lappin et al., 2003; Satter Syed et al., 1999; Selvam et al., 2007; Patruno et al., 2010; Sutbeyaz et al., 2009; Zhang et al., 2007; Tsang et al., 2009; Cvetkovic and Cosic, 2009).

The contradictions of LFI-EMFs on health-promoting effects are due to several factors, among them: the lack of standardized experimental circumstances; the unsystematic application of artificial LFI-EMF signals; and furthermore the cell type-specific redox status can also be responsible for the effects of electromagnetic expositions (Simkó, 2007).

Too long expositions of LFI-EMF treatments are also extremely problematic. During LFI-EMF experiments and treatments, LFI-EMF radiations with a short-term exposition (less than 45 min) can facilitate the immune system and cellular processes* (for example, through redox activation processes), but a long-term or continuous exposition to LFI-EMFs causes a decline in cytoprotection and can shift the redox and calcium homeostasis of cells (Di Carlo et al., 2002; Regoli et al., 2005).

***LFI-EMF exposition → stimulation of cellular membrane NADPH oxidase activity → superoxide redical generation O_2^- → increased activity of calcium channels Ca^{2+} and lipoxygenases → start of arachidonsav cascade and lipid peroxidation processes → expansion of signaling pathways in cells.**

EMOST system

Our EMOST medical device can detect and scene non-linear, bioelectric and bioelectromagnetic signals of the patient (Bókkon et al., 2010, 2011a, 2011b). The collected signals from patients' skin are processed by preprogrammed EMOST device (Fig. 1). The patients are treated by preprogrammed signals of EMOST device (frequencies are in the range of 1 Hz - 1 MHz; intensity range between 0.1-10 micro Teslas, via very special input/output flat electrodes). A particular feature of our EMOST method - compared to many

electromagnetic equipments - is that the patient's own bioelectromagnetic signals, which are detected from skin are processed via analogue manner (non-digitalized) inside the EMOST device. This signals are transmitted back via a flat electrode radiator through different band/signal combinations, with some amplification (-20dB- +60dB), to the skin's surface on the opposite side and extended by the higher range sounds of the signal. The special analogous signal process of EMOST device makes it possible that the biophysical information content of detected and back-transmitted electromagnetic signal is much larger than in digitized methods.

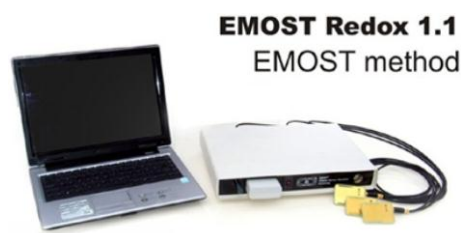

FIGURE 1 EMOST Redox 1.1 Medical Device (Certificate: HU11/6192) controlled by a personal computer.

Some possible effects of LFI-EMFs

Many possible mechanisms of various classical and quantum models have been suggested to elucidate the influence of LFI-EMFs in living systems (Binhi, 1999; Bókkon and Salari, 2010). A growing body of evidence suggested that several effects of LFI-EMFs therapies can be elucidated (or connected) by redox regulation and membrane-bound receptor mechanisms (Bauréus et al., 2003; Foster, 2003; Mathie et al., 2003). In addition, many experiments have revealed that reactive oxygen and nitrogen species as well as their derivatives act as essential signals in intracellular and intercellular communication (Dröge, 2002; Bókkon and Antal, 2011; Feissner et al., 2009; Kishida and Klann, 2007; Massaad and Klann, 2011; Powers et al., 2011; Valko et al., 2007; Zhang and Gutterman, 2007). The effect of LFI-EMFs on cell membranes and membrane-bound receptors can stimulate Ca²⁺-related pathways and free radical and redox-regulated processes. Thus, some of the fundamental effects of the EMOST treatment may be achieved via the redox balance of the body. It is likely that EMOST method can convey the detected and changed electromagnetic patterns of defective cells for surrounding and other cells, which facilitates intercellular communication via redox sensitive biochemical processes, and help restoration of homeostasis.

Biophysical therapeutic opportunities by LFI-EMF

Although modern pharmacology has made considerable progress in the medication of various diseases, we should also recognize that in many cases pharmacology treatments could be ineffective. In these cases, the biophysical LFI-EMF methods may offer some additional opportunities, because in various diseases, living cells do not only show altered biochemical processes but also generate altered non-linear bioelectric and bioelectromagnetic signals. Since each patient has a unique description of his/her own particular diseases, application of bioelectromagnetic own signals (EMOST) of patients for therapeutic applications may be effective especially compared to the diverse, artificial electromagnetic signals.

EMOST: phantom pain, sleep and mood quality

Recently, we presented our results regarding the effectiveness of the EMOST treatment (for six sessions) and the reduction of phantom limb pain under clinical circumstances (Bókkon et al., 2010, 2011a, 2011b). The EMOST method not only significantly reduced phantom pain, but also revealed additional benefits at most of the patients after expositions, such as improvement of their sleep and mood quality (Fig. 2).

We briefly mention here that we have established contact one year after our clinical EMOST experiments with those who took part in our research. However, there was no any further amputation in the EMOST treated patients during this year, and exposed patients reported a better general healthy states compared to sham exposed (control group). Pain is a key issue among veterans and members of the military due to increased survival rates from devastating injuries, including phantom limb pain after amputations (Ebrahimzadeh and Hariri, 2009; Wartan et a., 1997).

Since in many cases, various phantom pains can be disabling and can lead to a lifelong struggle with chronic pain, our EMOST method may offer a new possibility for the reduction of individual phantom pains.

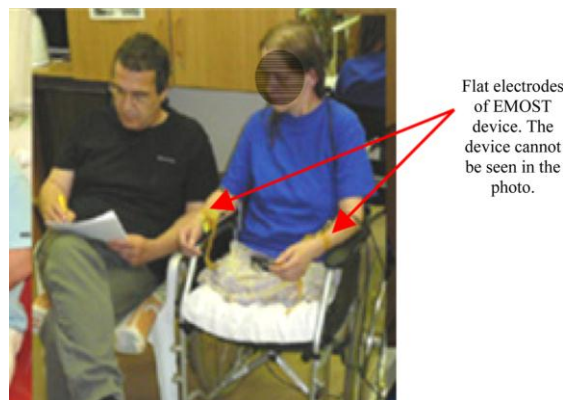

FIGURE 2 Treatment of amputees by EMOST in the clinic.

Stress responses

Task stressors are a common problem in police officers, soldiers, veterans, as well as in special commandos (Carlier et al., 2000; Renck et al., 2002; Miller, 2011). The exposure to diverse violent situations, witnessing distressing events and seeing victims are some of the task related stressors. These task stress induced symptoms can range from mild to severe.

Traumatic stress experiences often produce peritraumatic stress responses during and immediately after effects of trauma and in subsequent acute and posttraumatic stress responses in stress exposed subjects. However, the perception of stress is individual dependent. What is stressful to **X** person may not cause stress in **Y** person, because it depends on the person's previous experiences, emotional and mental states.

Sleep disturbances and interpersonal problems are highly prevalent in military and police subjects with various scales of stress disorders that are associated with substantial comorbidities and increased healthcare risks (Capaldi et al., 2011). PTSD symptoms may include nightmares, disturbing thoughts, re-experiencing phenomena, being socially detached from family and friends, hyper-arousal (such as feeling angry, irritable), etc.

Several evidences indicated that traumatic stress exposures and PTSD are common anxiety disorders in military and police subjects as well as in normal populations and can be associated with cardiovascular diseases, chronic fatigue syndrome, musculoskeletal disorders, etc. (Boscarino, 2004). People with PTSD are more likely to have hypertension, obesity, hyperlipidemia, and cardiovascular disease.

The biological processes that account for the observed associations between PTSD and cardiovascular disease may relate to dysregulation of the hypothalamic-pituitary-adrenal (HPA) axis and for continual over-stimulation of the autonomic nervous system that can promote the increases in blood pressure and lipid levels (Bedi and Arora, 2007).

Immune function changes in PTSD subjects may also influence circulating levels of interleukin-6 (IL-6), IL-1, tumor necrosis factor (TNF), and C-reactive protein (CRP) (Rohleder and Karl, 2006). However, inflammatory mediators such as TNF, CRP, and IL-6, can stimulate atherosclerosis. Interactions among the immune and neuroendocrine systems may partly account for associations between PTSD and chronic disease outcomes.

Psychological and medical treatments for PTSD include group or individual psychotherapy (for example, cognitive-behavioral therapy) and pharmacotherapy such as the use of selective serotonin reuptake inhibitors (Spoont et al., 2010).

EMOST treatment of police commandos during training exercise

In 2011, we performed some EMOST treatments of twelve Hungarian police commandos (elite forces) during their hard training exercise. During commando trainings, police officers had been exposed to very difficult physical and psychological conditions for three weeks. We provided our treatments (with official permission) on three consecutive days in the last week of exercising. The commandos came and went for shooting practice, physical training etc., and when they have a little pause, we performed EMOST treatments. As the Figure 3 shows, commandos were lying on the hard tables (sometimes with weapons) during EMOST treatments. So, the situation was very realistic.

The commandos were asked to rate their physical and psychological conditions on the 0–10 verbal numerical rating scale prior to the treatment and after the treatment during each three days. We also measured their cardiovascular risks prior to the treatments and after the treatments, and studied the speed of their reflexes via a simple task. Following the trend of the three treatments, after the third treatment, the studied parameters clearly showed a downward trend in cardiovascular risks, an improved physical and psychological conditions as well as a slightly increased reflex.

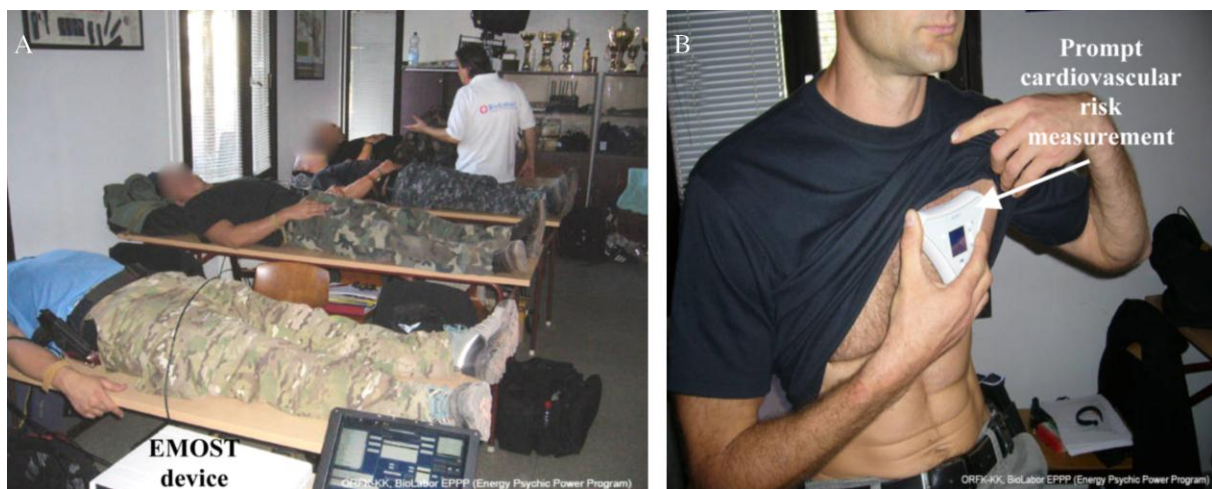

FIGURE 3 (A) Commandos were lying on the hard tables during EMOST treatments. (B) Prompt measure of cardiovascular risk.

EMOST treatments during flood disaster in Felsőzsolca, Hungary

Felsőzsolca is a small town in North-East of Hungary. In June, 2010 the biggest flood hit Felsőzsolca. Out of a total of 2200, about 1800 houses were damaged, and over 200 houses collapsed by the river Sajó. In addition to local residents, hundreds of soldiers, firefighters and

volunteers helped to save lives. The local government leaders as well as military and firefighter commanders continuously managed the rescue processes. Many managers had no sleep in 48 hours, and several residents suffered PTSD. Some voluntary psychologists also tried to reduce the extreme psychological stress caused by the flood.

Since our several years of EMOST application and our experiments indicated that EMOST can produce prompt effect to reduce stress and fatigue levels and to improve sleep and mood quality in patients, our BioLabor group also took part as volunteers in Felsőzsolca rescue-actions by EMOST treatments of several commanders and local residents that were exhausted at the border (see Figure 4 with our photos). We have treated about 80 managers and residents by some of special EMOST regeneration program. Most of the treated subjects rendered benefit improvements after 40 min treatment reported their reduced stress and fatigue levels and improved mood quality and concentration ability.

After traumatic stress (that frequently result in peri-traumatic stress), the sooner we use a variety of therapies, the smaller the chance to develop acute or posttraumatic stress state. However, biophysical LFI-EMF treatments may offer a special and prompt help in many particular situations.



FIGURE 4 Our photos have been taken in Felsőzsolca. (A) EMOST treatments of exhausted and stressed local residents, soldiers, firefighters. (B) Our car and local residents in a flooded street in Felsőzsolca, on June, 2010. (C) Residents used a boat to cross a flooded street in Felsőzsolca.

Preliminary experiments: Single EMOST treatment effect on electrocardiogram and the serum concentration of urea, albumin, cortisol, chloride, CPK, TSH, and CRP

We performed some preliminary experiments on twelve members of our BioLabor regarding the effectiveness of single EMOST treatment on some serum parameters and electrocardiogram (ECG). ECG results did not show statistically significant improvement after single EMOST treatment. In contrast, some serum factors such as uric acid, albumin, cortisol, chloride, Creatine phosphokinase (CPK), Thyroid stimulating hormone (TSH), C-reactive protein (CRP) indicated some remarkable changes following one treatment.

Cortisol, TSH, CRP, and CPK serum concentrations were reduced in the most of us. The albumin concentration usually showed a slight decrease and the uric acid concentration increased in almost all cases. Chloride level of serum showed a slight increase in almost every case. Of course, these few preface experiments have no great importance, but indicate EMOST treatment may reduce stress factors and affect on the redox/free radical processes as numerous studies reported regarding to the effect of low-frequency and intensity electromagnetic fields.

For example, cortisol levels were decreased in most of the members of our BioLabor after one EMOST treatment. Cortisol is a (glucocorticoid) steroid hormone that produced by the adrenal cortex in response to stress (Inslicht et al., 2011). Its major functions are, among them, to increase blood sugar through gluconeogenesis and suppress the immune system, but recent studies revealed that glucocorticoids (cortisol) have both stimulatory and suppressive effects on immune responses that are dependent on the GC concentration (Yeager et al., 2008).

Uric acid concentration increased in almost all cases after single EMOST treatment. However, uric acid is strong reducing agents (electron donors) and potent antioxidants (Warning, 2002). In humans, about the half the antioxidant ability of blood plasma comes from uric acid (Maxwell et al., 1997).

Chloride level also showed a slight increase in almost every case. Chloride is a prominent negatively charged ion in the blood, where it represents about 70% of the body's total negative ion content. However, chloride level has essential role of blood pH value that can influence pH-dependent redox/free radical processes. It seems that EMOST treatments may transiently potentiate functional redox processes.

However, we have started a large-scale, controlled testing of EMOST treatments (with forty subjects and with sham exposed controls) regarding its effectiveness on serum parameters and electrocardiogram. We hope that we can report the results in the near future.

Discussion and Conclusions

We have to stress again that our goal was not the presentation of clinical or controlled trials, but show the non ionizing electromagnetic management under real-life and also in unique conditions.

One may argue that the presented beneficial effects of our EMOST treatments were due to the placebo effect. However, it is unlikely that EMOST treatments could produce placebo effect on eighty subjects under flood disaster. In addition, during many years of EMOST application, we also effectively treated hundreds of children and babies with diverse health problems. It is also hardly possible that EMOST treatments could make placebo effects on babies. Furthermore, our recently published results on the effectiveness of the EMOST in reduction of phantom limb pain as well as improvement of the quality of sleep and mood in subjects under clinical circumstances also support the real effectiveness of EMOST.

Because the EMOST method based on non-linear, bioelectric and bioelectromagnetic signals of patients, it offers tailor-made opportunities. In addition, it is not realistic to apply a large number of psychologists under unexpected events and disaster conditions.

The presented EMOST application (Electro-Magnetic-Own-Signal-Treatment) under disaster conditions and commando training, may point out a further possible way of healing therapies in addition to the modern pharmacologic and psychological methods. We should also consider that the sooner we use a variety of therapies, the smaller the chance to develop acute or posttraumatic stress status after unexpected and disaster situations.

The aforementioned few preliminary experiments on members of our BioLabor regarding the efficiency of single EMOST treatment on serum parameters and electrocardiogram indicated that it is worthy to perform a large-scale, controlled testing that we have started.

Besides, not only for stress management should be considered, but also improve mental and physical states, concentration, cognitive and situation analysis abilities of exhausted troops and policemen after unexpected and catastrophic events.

In summary, we should consider biophysical electromagnetic managements as a further possible way of healing therapies in addition to the pharmacologic and psychological methods, especially under unique, unexpected and disaster situations.

CONFLICT OF INTEREST

The authors report no conflicts of interest. The authors alone are responsible for the content.

ACKNOWLEDGEMENTS

Authors gratefully thank the police contribution to perform our experiments for Géza Simon, Colonel, Director of Hungarian National Police and Provost Duties, Armed Marshalls Training Center (ORFK-KK). Authors also gratefully thank for commandos their participation in our survey related to EMOST treatments. Bókkon's URL: www.bokkon-brain-imagery.5mp.eu; BioLabor's URL: www.biolabor.org

References

- Baldi, E., Baldi, C., Lithgow, B. J. (2007). A pilot investigation of the effect of Extremely low frequency pulsed electromagnetic fields on humans' heart rate variability. *Bioelectromagnetics* 28:64–68.
- Barzelai, S., Dayan, A., Feinberg, M. S., et al. (2009). Electromagnetic field at 15.95-16 Hz is cardio protective following acute myocardial infarction. *Ann. Biomed. Eng.* 37:2093–2104.
- Bauréus, K. C. L., Sommarin, M., Persson, B. R., et al. (2003). Interaction between weak low frequency magnetic fields and cell membranes. *Bioelectromagnetics* 24:395–402.
- Bedi, U. S., Arora, R. (2007). Cardiovascular manifestations of posttraumatic stress disorder. *J. National Med. Assoc.* 99:642–649.
- Binhi, V. N. (1999). An analytical survey of theoretical studies in the area of magnetoreception. In: Repacholi, M. H., Rubtsova, N. B., Muc, A. M. eds. *Electromagnetic Fields: Biological Effects and Hygienic Standardization*. (pp. 155–170). World Health Organization. Switzerland, Geneva.
- Bókkon, I., Antal, I. (2011). Schizophrenia: redox regulation and volume transmission. *Curr. Neuropharm.* 9:289–300.
- Bókkon, I., Salari, V. (2010). Information storing by biomagnetites. *J. Biol. Phys.* 36:109–120.
- Bókkon, I., Till, A., Erdöfi-Szabó, A. (2010). Phantom Pain Reduction by Non-ionizing Electromagnetic Treatment. *Hungarian Epidemiology* 7/4/Suppl.:15.
- Bókkon, I., Till, A., Erdöfi-Szabó, A. (2011a). Non-ionizing Electro-Magnetic-Own-Signal-Treatment. *Eur. Biophys. J.* 40 (Suppl. 1): S191.
- Bókkon, I., Till, A., Grass, F., Erdöfi-Szabó, A. (2011b). Phantom pain reduction by electromagnetic treatment. *Electromagn. Biol. Med.* 30:115–127.
- Boscarino, J. A. (2004). Posttraumatic stress disorder and physical illness: results from clinical and epidemiologic studies. *Ann. N. Y. Acad. Sci.* 1032:141–153.

- Capaldi, V. F., 2nd, Guerrero, M. L., Killgore, W. D. (2011). Sleep disruptions among returning combat veterans from Iraq and Afghanistan. *Mil. Med.* 176:879–888.
- Carlier, I. V., Voerman, A. E., Gersons, B. P. (2000). The influence of occupational debriefing on post-traumatic stress symptomatology in traumatized police officers. *Br. J. Med. Psychol.* 73:87–98.
- Cvetkovic, D., Cosic, I. (2009). Alterations of human electroencephalographic activity caused by multiple extremely low frequency magnetic field exposures. *Med. Biol. Eng. Comput.* 47:1063–1073.
- Di Carlo, A., White, N., Guo, F., et al. (2002). Chronic electromagnetic field exposure decreases HSP70 levels and lowers cytoprotection. *J. Cell. Biochem.* 84: 447–454.
- Dröge, W. (2002). Free Radicals in the Physiological Control of Cell Function. *Physiol. Rev.* 82: 47–95.
- Ebrahimzadeh, M. H., Hariri, S. (2009). Long-term outcomes of unilateral transtibial amputations. *Mil. Med.* 174:593–597.
- Feissner, R. F., Skalska, J., Gaum, W. E., Sheu, S. S. (2009). Crosstalk signaling between mitochondrial Ca²⁺ and ROS. *Front. Biosci.* 14:1197–1218.
- Foster, K. R. (2003). Mechanisms of interaction of extremely low frequency electric fields and biological systems. *Rad. Prot. Dosim.* 106:301–310.
- Ghione, S., Seppia, C. D., Mezzasalma, L., Bonfiglio, L. (2005). Effects of 50 Hz electromagnetic fields on electroencephalographic alpha activity, dental pain threshold and cardiovascular parameters in humans. *Neurosci. Lett.* 382:112–117.
- Inslicht, S. S., Otte, C., McCaslin, S. E., et al. (2011). Cortisol Awakening Response Prospectively Predicts Peritraumatic and Acute Stress Reactions in Police Officers. *Biol. Psychiatry* Epub ahead of print.
- Kishida, K. T., Klann, E. (2007). Sources and targets of reactive oxygen species in synaptic plasticity and memory. *Antioxid. Redox Signal.* 9:233–244.
- Kumar, V. S., Kumar, D. A., Kalavani, K., et al. (2005). Optimization of pulsed electromagnetic field therapy for management of arthritis in rats. *Bioelectromagnetics* 26:431–439.
- Lappin, M. S., Lawrie, F. W., Richards, T. L., Kramer, E. D. (2003). Effects of a pulsed electromagnetic therapy on multiple sclerosis fatigue and quality of life: a double-blind, placebo controlled trial. *Altern. Ther. Health Med.* 9:38–48.
- Mach, Q. H., Persinger, M. A. (2009). Behavioral changes with brief exposures to weak magnetic fields patterned to stimulate long-term potentiation. *Brain Res.* 1261:45–53.

- Mancuso, M., Ghezzi, V., Di Fede, G. (2007). Utilization of extremely low frequency (ELF) magnetic fields in chronic disease; five years experience: three case reports. *Electromagn. Biol. Med.* 26:311–313.
- Massaad, C. A., Klann, E. (2011). Reactive oxygen species in the regulation of synaptic plasticity and memory. *Antioxid. Redox Signal.* 14:2013–2054.
- Mathie, A., Kennard, L. E., Veale, E. L. (2003). Neuronal ion channels and their sensitivity to extremely low frequency weak electric field effects. *Rad. Prot. Dosim.* 106:311–316.
- Maxwell, S. R., Thomason, J. H., Sandler, D., et al. (1997). Antioxidant status in patients with uncomplicated insulin-dependent and non-insulin-dependent diabetes mellitus. *Eur. J. Clin. Invest.* 27:484–490.
- Miller, G. (2011). The invisible wounds of war. Healing the brain, healing the mind. *Science* 333:514–517.
- Nishimura, T., Tada, H., Guo, X., et al. (2011). A 1- μ T extremely low-frequency electromagnetic field vs. sham control for mild-to-moderate hypertension: a double-blind, randomized study. *Hypertens. Res.* 34:372–377.
- Patrino, A., Amerio, P., Pesce, M., et al. (2010). Extremely low frequency electromagnetic fields modulate expression of inducible nitric oxide synthase, endothelial nitric oxide synthase and cyclooxygenase-2 in the human keratinocyte cell line HaCat: potential therapeutic effects in wound healing. *Br. J. Dermatol.* 162:258–266.
- Powers, S. K., Talbert, E. E., Adhietty, P. J. (2011). Reactive oxygen and nitrogen species as intracellular signals in skeletal muscle. *J. Physiol.* 589:2129–2138.
- Regoli, F., Gorbi, S., Machella, N., et al. (2005). Pro-oxidant effects of extremely low frequency electromagnetic fields in the land snail *Helix aspersa*. *Free Radic. Biol. Med.* 39:1620–1628.
- Renck, B., Weisaeth, L., Skarbö, S. (2002). Stress reactions in police officers after a disaster rescue operation. *Nord. J. Psychiatry* 56: 7–14.
- Rohleder, N., Karl, A. (2006). Role of endocrine and inflammatory alterations in comorbid somatic diseases of post-traumatic stress disorder. *Minerva Endocrinol.* 31:273–288.
- Sandyk, R. (1997). Treatment with electromagnetic fields reverses the long-term clinical course of a patient with chronic progressive multiple sclerosis. *Int. J. Neurosci.* 90:177–185.
- Satter Syed, A., Islam, M. S., Rabbani, K. S., Talukder, M. S. (1999). Pulsed electromagnetic fields for the treatment of bone fractures. *Bangladesh. Med. Res. Counc. Bull.* 25:6–10.

- Selvam, R., Ganesan, K., Narayana Raju, K. V., et al. (2007). Low frequency and low intensity pulsed electromagnetic field exerts its antiinflammatory effect through restoration of plasma membrane calcium ATPase activity. *Life Sciences* 80:2403–2410.
- Simkó, M. (2007). Cell type specific redox status is responsible for diverse electromagnetic field effects. *Curr. Med. Chem.* 14:1141–1152.
- Spoont, M. R., Murdoch, M., Hodges, J., Nugent, S. (2010). Treatment receipt by Veterans after a PTSD diagnosis in PTSD, mental health, or general medical clinics. *Psychiatric Services* 61:58–63.
- Sutbeyaz, S. T., Sezer, N., Koseoglu, F., Kibar, S. (2009). Low-frequency pulsed electromagnetic field therapy in fibromyalgia: a randomized, double-blind, sham-controlled clinical study. *Clin. J. Pain.* 25:722–728.
- Tsang, E. W., Koren, S. A., Persinger, M. A. (2009). Specific patterns of weak (1 microTesla) transcranial complex magnetic fields differentially affect depression, fatigue, and confusion in normal volunteers. *Electromagn. Biol. Med.* 28:365–373.
- Valko, M., Leibfritz, D., Moncol, J., et al. (2007). Free radicals and antioxidants in normal physiological functions and human disease. *Int. J. Biochem. Cell. Biol.* 39:44–84.
- Waring, W. S. (2002). Uric acid: an important antioxidant in acute ischaemic stroke. *QJM.* 95: 691–693.
- Wartan, S. W., Hamann, W., Wedley, J. R., McColl, I. (1997). Phantom pain and sensation among British veteran amputees. *Br. J. Anaesth.* 78:652–659.
- Yeager, M. P., Pioli, P. A., Wardwell, K., et al. (2008). In vivo exposure to high or low cortisol has biphasic effects on inflammatory response pathways of human monocytes. *Anesth. Analg.* 107:1726–1734.
- Zhang, D. X., Gutterman, D. D. (2007). Mitochondrial reactive oxygen species-mediated signaling in endothelial cells. *Am. J. Physiol. Heart Circ. Physiol.* 292:H2023–H2031.
- Zhang, X., Zhang, J., Qu, X., Wen, J. (2007). Effects of different extremely low-frequency electromagnetic fields on osteoblasts. *Electromagn. Biol. Med.* 26:167–177.

Changing in Cardio-stress

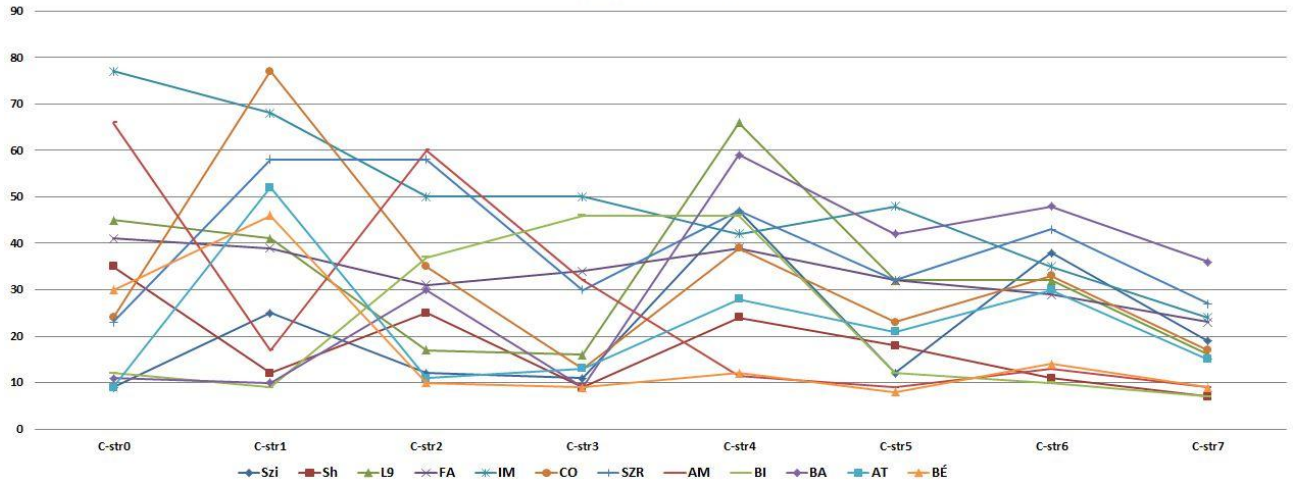

Changing in capacity, squeezes/min

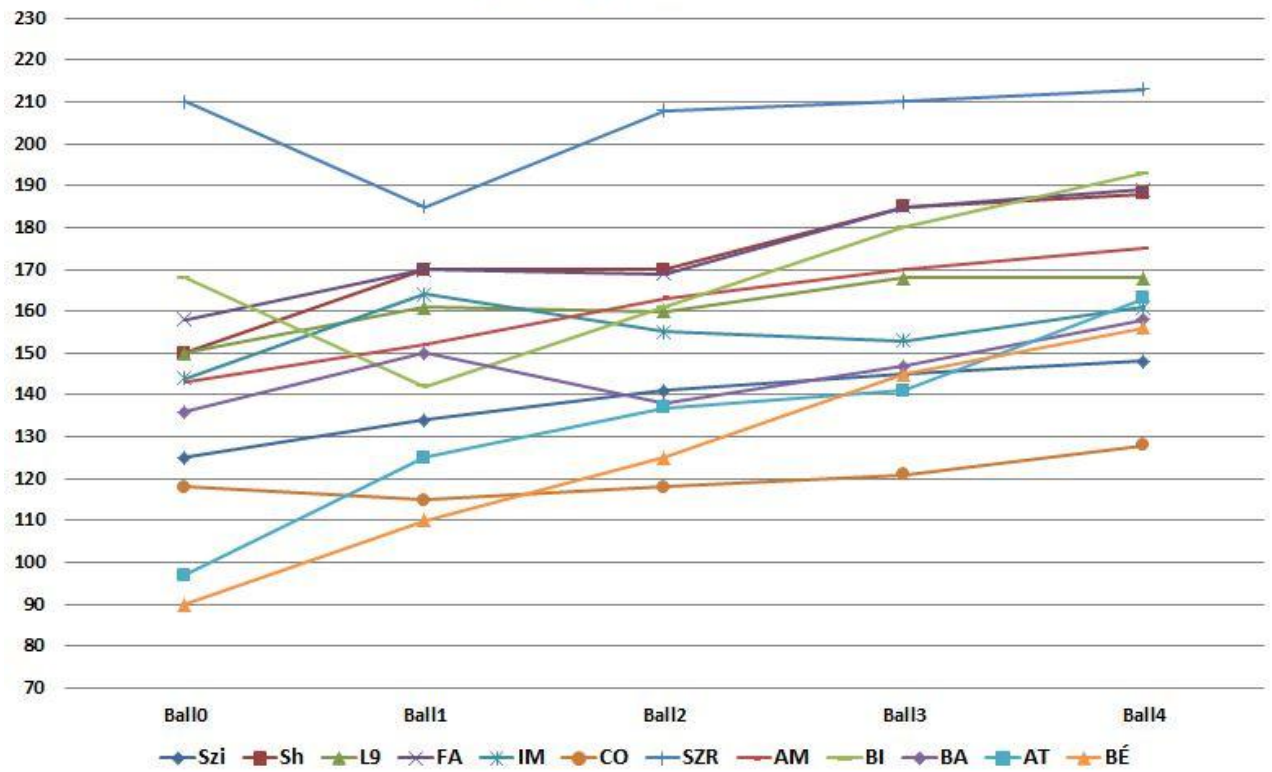

Changing in Reflex speed/mm

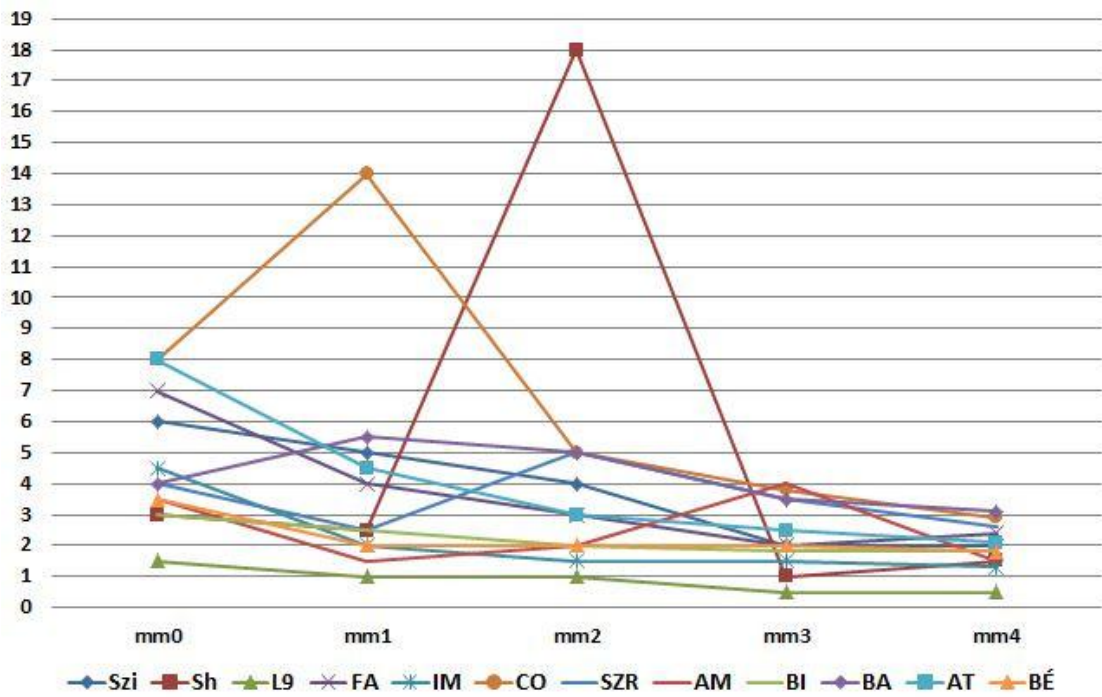

Subjective: changing in Vitality

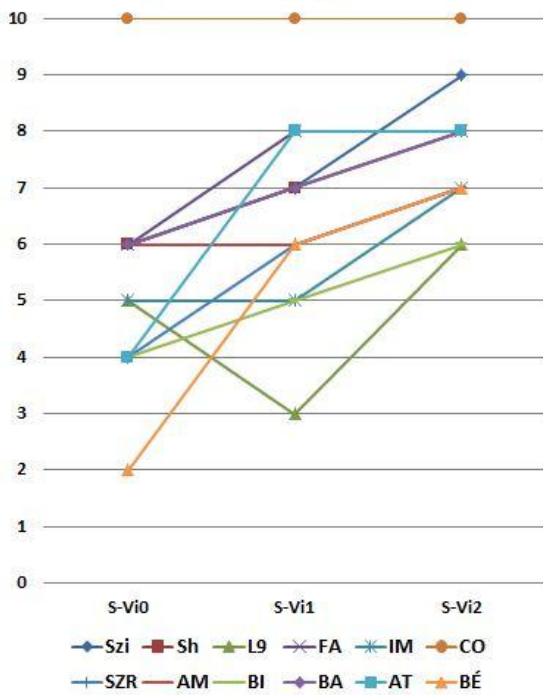

Subjective: changing in Psychical balance

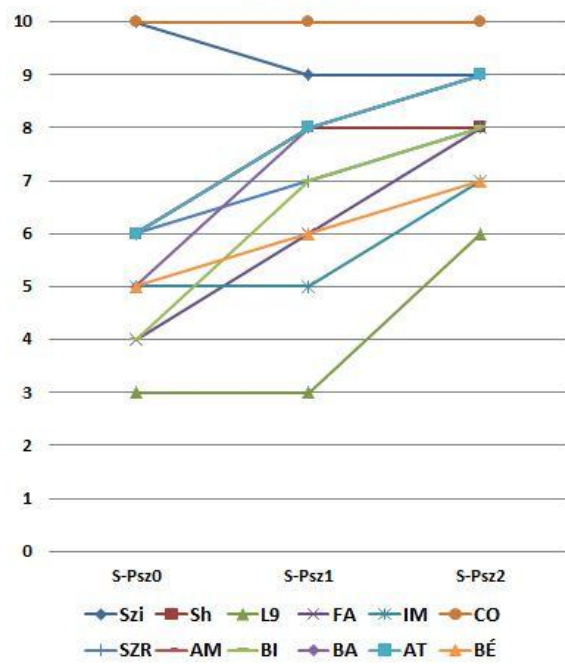

translation of clinical reference letter



ORSZÁGOS
ORVOSI
REHABILITÁCIÓS
INTÉZET

National Institute for Medical Rehabilitation, Budapest, Hungary
Budapest, Szanatórium utca 19. <http://rehabint.hu/welcome.htm>

Dear Mr. Dr. Attila Erdőfi-Szabó,

Since 2010 we have been using EMOST method at our department in the process of rehabilitation following limb amputation together with the procedures stated in the rehabilitation protocol. We have been using this technology aiming mainly at reducing and stopping phantom pain and reducing the post operation post traumatic stress of the patients having been operated on. After the medical attendance aiming at the above mentioned goals we experienced the following results:

- a) there is less formation of phantom pain after the operation
- b) higher number of decrease and stopping of phantom pain
- c) post traumatic stress of limb absence is significantly less in the treated patients
- d) healing of the wound is significantly faster, the stump can be strained much earlier
- e) sleep quality in treated patients is significantly better than in the non-treated ones
- f) psychological status of the patients treated is significantly more propitious than in non-treated ones

In our department we used this method with patients having defecation and urination problems which made the rehabilitation process more difficult and thus making their quality of life worse.

According to our experiences we can state that using the equipment for these purposes, defecation and urination malfunction of treated patients decreased significantly, including stool retention and urinary retention and the decrease and stop of incontinence caused by stress.

It is a particularly good result because of the limitation of motion and the high risk of motion deficits, because the imbalance of "freshly" Amputees and the the number of injuries caused by falling due to perceiving the not yet accepted altered body image can be significantly reduced.

Our experience also suggests that the central nervous system and autonomic nervous system treatments resulted in the patients body detection is better than in non treated patients.

This way getting used to artificial limb is quicker, and more efficient thus reducing the risk of falls and the consequential formation of necrosis of the stump, while the rehabilitation time improves.

As we have reported in the magazine *Electromagnetic Biology and Medicine*, we found that patients treated with our method are needed smaller proportion of reamputation so the positive results exist, thus long-term effects can be assumed.

According to our experience we have gained so far, the EMOST method and equipment is considered a promising method because of its beneficial and spectacular impact on the nervous system, the conductivity and the post traumatic stress.

On behalf of my colleagues and myself I claim to continue the collaboration in the research team's work, so that the procedure based on the further results can be included in the protocol of amputee rehabilitation.

I wish you success in your work,

18.06.2012, Budapest

Dr. Attila TILL, Chief Medical Head of Department, Amputation Surgical Dep.,
National Institute for Medical Rehabilitation



Országos Orvosi Rehabilitációs Intézet
1528 Budapest XII., Szanatórium u. 19.
Telefon: 391-1944, Fax: 391-1977
ÁNTSZ-016010201
Amputációs Sebészeti osztály
osztályvezető főorvos: dr. Till Attila

Dr. Till Attila,
osztályvezető főorvos



ORSZÁGOS
ORVOSI
REHABILITÁCIÓS
INTÉZET

Amputációs Sebészeti Osztály

Osztályvezető: dr. Till Attila

1121 Budapest, XII. Szanatórium u. 19.

Tel.: +36/1/391-1900, 391-1901 Fax: +36/1/200-2698

e-mail: a.till@rehabint.hu

Cím: Dr. Erdőfi-Szabó Attila Ph.D.

BioLabor Biofizikai- és Laboratóriumi Szolgáltató Kft.

Tisztelt Dr. Erdőfi-Szabó Attila úr!

2010 májusa óta alkalmazzuk osztályunkon az EMOST módszert az alsó végtag amputációt követő rehabilitáció folyamatában, a rehabilitációs protokollban szereplő eljárások mellett. Az elmúlt időszakban főként célzottan, a fantomfájdalom csökkentése, megszüntetése, illetve a betegek műtétet követő „post-traumás” stressz csökkentése céljából használtuk a technológiát. A fent meghatározott célokból indított kezelések után az alábbi eredményeket tapasztaltuk:

- a) a fantomfájdalom kialakulása kisebb arányú a műtétet követően kezelt betegeknél
- b) a fantomfájdalom csökkenése, megszűnése nagyobb arányú a kezelt betegeknél
- c) a végtagvesztést követő post-traumás stressz jelentősen kisebb a kezelt betegeknél
- d) a sebgyógyulás jelentősen gyorsabb, a csonk hamarabb terhelhető a kezelt betegeknél
- e) a kezelt betegek alvásminősége jelentősen jobb a nem kezeltéknél
- f) a kezelt betegek pszichés állapota jelentősen kedvezőbb a nem kezeltéknél

Az osztályunkon, olyan betegeken is alkalmazzuk a módszert, akiknél széklet- és vizeletürítési panaszok is nehezítették a rehabilitáció folyamatát, egyben rontották a betegek életminőségét. Tapasztalataink alapján kijelenthetjük, hogy a készülék e célú kezelési programjainak hatására a kezelt személyek ürítési zavarai is jelentősen csökkennek, beleértve a széklet- vizelet visszatartás illetve a stressz okozta vizelet inkontinencia csökkenését, megszűnését is. Ez a mozgás korlátozottság és a nagy kockázatot jelentő mozgásdeficit miatt kiemelten jó eredmény, hiszen a „friss” amputáltak egyensúlyzavara és a még el nem fogadott, megváltozott testkép okozta gyakran észlelt eleséséből származó sérülések száma jelentősen mérsékelhető.

Tapasztalatunk alapján kijelenthető, hogy a központi idegrendszeri és autonóm idegrendszeri kezelések eredményeképpen a kezelt betegek testérzékelése is jobb a nem kezelt betegeknél, ez a művégtag megszokását gyorsítja, a használatát javítja, így csökkenti az elesés kockázatát, valamint a következményes csonkelhalás kialakulását, egyúttal a rehabilitációs időt is javítja. Ahogy arról az Electromagnetic Biology and Medicine c. szaklapban beszámoltunk, tapasztaltuk, hogy a kezelt betegeknél a reamputáció szükségessége kisebb arányú, az elért kedvező eredmények tartósan fennállnak, így a hosszabb távú hatásmegtartás vélelmezhető. Az eddig szerzett tapasztalataink alapján az EMOST módszert és készüléket az idegrendszerre, az ingervezetésre, és a „post-traumás” stresszre gyakorolt jótékony és

látványos hatása miatt ígéretes módszernek tekintjük. Munkatársaim és magam nevében kijelentjük, hogy továbbiakban is közreműködünk a kutató team munkáiban, hogy az eljárás a további eredmények alapján a rehabilitációs protokollokba illeszthetővé válhasson. Munkájukhoz sok sikert kívánok!

Budapest, 2012. június 18.



Dr. Till Attila,
osztályvezető főorvos

Országos Orvosi Rehabilitációs Intézet
1528 Budapest XII., Szanatórium u. 19.
Telefon: 391-1944; Fax: 391-1977
ÁNTSZ-016010201
Amputációs Sebészeti osztály
osztályvezető főorvos: dr. Till Attila

Publikációk:

1. Szombathelyi Zs. – Kárpáthy E. – **TILL A.**
Comparative in vitro study of RGH-2981, a new peripheral blood flow enhancer on animal and pathological human arteries = Pol. J. Pharmacol. Pharm. 1989. 41. 591-595. p.
IF: 0,195
Cit.: -
34. **TILL A.**
Amputáció és rehabilitáció időskorban= Családorvosi Fórum 2010. február. 28-30.p.
35. **TILL A.**
Alsó és felső végtagi protetika
in: Rehabilitációs orvoslás /szerk: Vekerdy-Nagy Zsuzsanna – Medicina Könyvkiadó Zrt., Budapest, 2010.295-299.p.
36. **TILL A.**
Amputáltak és dysmeliások rehabilitációja
in: Rehabilitációs orvoslás /szerk: Vekerdy-Nagy Zsuzsanna – Medicina Könyvkiadó Zrt., Budapest, 2010.574-583.p.
37. Bókkon I., **TILL A.**, Erdőfi-Szabó A.: A Phantom pain reduction by non- ionizing Electromagnetic treatment = Hungarian Epidemiology, = 010;7/4/Suppl. : 15.p. Abstract.
38. Bókkon I., **TILL A.**, Erdőfi-Szabó A.: Phantom pain reduction by non-ionizing electromagnetic treatment = Nature Precedings <http://dx.doi.org/10.1038/npre.2010.4989.1> 2010.
39. Bókkon I., **TILL A.**, Erdőfi- Szabó A.: Phantom pain reduction by low frequency and intensity electromagnetic fields: redox-related neural plasticity = Electromagnetic Biol.Med.
IF: 0,729
40. Bókkon I., **TILL A.**, Erdőfi-Szabó A.: Non-ionizing electromagnetic-own-signal-treatment =European Biophysics Journal. Vol.40.Supplement 1. August 2011. P-576.
41. Göbl A.,**TILL A.**, Rembeczki L.: tapasztalataink a „ problémás” diabeteses lábsebek gyógyításában a hiperbárikus oxigénterápia adjuvans alkalmazásával = Diabetologia Hungarica. Supplement.12. 04 .2012. P-68.

(translation of reference letter)



ARMY Independent Voluntary Health Insurance Fund

1392 Budapest, Pf.:295 web:www.honvedep.hu E-Mail: honvedep@honvedep.hu
Tel:(+36 1) 412-3320,412-3321; HM 277-95 Fax:239-6749 HM fax: 278-94
1135 Budapest Aba utca 4.

Additional ARMY Independent Voluntary Health Insurance Fund was launched in March 1996 as a sector insurance and it has been opened as publicly found since 2005.

The number of institutional employers are over 100, who are paying their employer contribution. The fund's largest employer is the Ministry of Defence. The membership of health fund exceeds 30,000 people.

We have had a health service contract between our Health Service and Your Company for around three years, to provide the preventive care, screening, and health needs of our members.

During the last period of the staff took health services, which included medical tests after developing Personal Health Plans and treatments.

The treatments aimed at health prevention and rehabilitation, mainly:

- to improve physical well-being
- improving vital capacity
- treating post-traumatic stress
- other e.g. wound healing, digestion, allergies, pain relief

Recently many of our members took advantage of the advanced services of your Health Service. Our members consider the service appropriate, effective and they are still being used.

Your professional commitment is demonstrated by being on demand at our events free of charge and by giving free presentation of your services. Hereby I would like to thank you for your work at our recent common successful introduction in Veszprém village (at Military Day).

I wish you good luck to your work, and I hope for further successful cooperation,
18.06.2012. Budapest, Hungary, EU

Dr. Miklós Rékai

managing director,

ARMY Independent Voluntary Health Insurance Fund

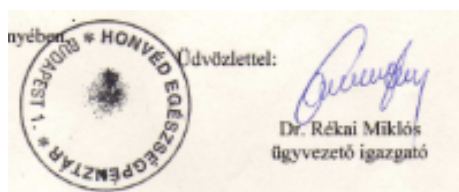



Dr. Erdőfi-Szabó Attila Ph.D.,
BioLabor Biofizikai- és Laboratóriumi Szolgáltató Kft.

Tisztelt Dr. Erdőfi-Szabó Úr!

A Honvéd Önkéntes Kölcsönös Kiegészítő Egészségbiztosító Pénztár (továbbiakban: Pénztár) 1996. márciusában alakult ágazati pénztárként, 2005. áprilisától országos nyílt pénztárként működik. A munkáltatói hozzájárulást fizető munkáltatók száma meghaladja a 100-at. A pénztár legnagyobb munkáltatói tagja a Honvédelmi Minisztérium. A pénztár taglétszáma meghaladta a 30000 főt.

A Pénztárunk és Önök között közel három éve áll fenn szolgáltatói szerződés, tagságunk megelőző ellátási, szűrési, egészségvédelmi igényének biztosítása érdekében. Az elmúlt időszak alatt az állomány magán egészségügyi szolgáltatásokat vett igénybe, melyek között orvosi vizsgálatokat követő személyes egészségtervek kialakítása és kezelések szerepeltek.

A kezelések egészségőrző és rehabilitációs célúak, melyek jellemzően:

- fizikai közérzet javítás
- vitálkapacitás növelés
- post-traumás stressz kezelés
- egyéb, pl. sebgyógyulás, emésztés, allergia, fájdalomcsökkentés.

Az elmúlt időszakban számos Pénztártagunk vette igénybe az Önök korszerű szolgáltatásait. Tagjaink a szolgáltatást megfelelőnek, eredményesnek találták, és jelenleg is folyamatosan igénybe veszik.

Szakmai elkötelezettségüket bizonyítja, hogy Pénztárunk rendezvényein, felkérésünkre Önön ellenszolgáltatás nélkül rendelkezésre állnak és térítésmentes bemutatót tartanak szolgáltatásaikról.

Ezúton mondok köszönetet legutóbbi sikeres Veszprémi közös bemutatkozásunkon végzett munkájukért.

Budapest, 2012. június 18. -n

További sikeres együttműködést reményében

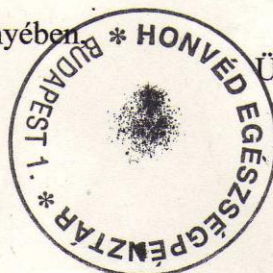

Üdvözlettel:

Dr. Rékai Miklós
ügyvezető igazgató



ORFK

Rendészeti Szervek Kiképző Központ

Lőképzés- és Intézkedéstaktikai Alosztály

Levélcím: 1097 Budapest, Vágóhid u. 11-13.; 1903 Budapest, Pf. 314

BM ☎:28-012 Városi ☎:476-3445 BM fax:28-062 Városi fax:476-3446

Egyetértek:

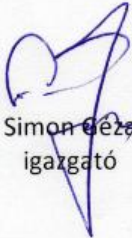
Simon Géza
igazgató

translation of reference letter

Hungarian National Police and Provost Duties, Armed Marshalls Training Center (ORFK-KK) Marksman- and Tactical Units Training Department

approved by Simon Géza

director

Referring to your report of 15 November 2011 concerning the efficiency of EMOST treatments on the staff taking part in the training program for special units during the period of 4-7 October 2011, I congratulate you on the achieved results.

While consulted the staff about the treatment I got positive feedback on the treatment only. You managed to achieve development and measurable decrease of stress load in training circumstances.

Special congratulations on the proven results which exceeded your estimated rate.

I am delighted that the technology has been tested first in the world in the (Hungarian) National Police and Provost Duties, Armed Marshalls Training Center Marksman- and Tactical Units Training Department in lifelike mission environment, in real situations.

I wish you good luck to your work and to effective adaptation of your method.

28.11.2011, Budapest,

Zoltan Laszlo SZABÓ, Ret. Police Lieutenant-Colonel,
Marksman- and Tactical Units Training Department Chief

Szabó Zoltan László t. alezredes
alosztályvezető



ORFK

Rendészeti Szervek Kiképző Központ
Lőkiképzés- és Intézkedéstaktikai Alosztály

Levél cím: 1097 Budapest, Vágóhíd u. 11-13.; 1903 Budapest, Pf. 314
BM ☎:28-012 Városi ☎:476-3445 BM fax:28-062 Városi fax:476-3446

Egyetértek:

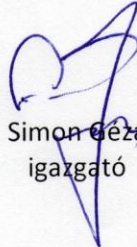

Simon Géza
igazgató

Dr. Erdőfi-Szabó Attila Ph.D.,
BioLabor Biofizikai- és Laboratóriumi Szolgáltató Kft.

Tisztelt Dr. Erdőfi-Szabó Attila Úr!

Hivatkozva 2011.11.15-i Beszámolójára, melynek tárgya a 2011.10.04-07. időszakban kiképzési programon résztvevő speciális rendőri feladatokat ellátó állományon végrehajtott EMOST típusú kezelések eredményessége, gratulálok, hogy a megküldött eredményeket elérte.

Az állomány körében folytatott konzultáció során a kezeléssel kapcsolatban csak pozitív visszajelzést kaptam. Sikerült teljesítmény növekedést és mérhető stressz terhelés csökkenést elérniük kiképzési helyzetben.

Külön gratulálok ahhoz, hogy a tapasztalt eredmények felülmúlták az Önök által előre megbecsült mértéket, és örömmel tölt el, hogy az ORFK RSZKK intézményben lett a világon először tesztelve életszerű bevetési környezetben a technológia.

Munkájukhoz, és a módszer további eredményes alkalmazásához sok sikert kívánok,

Budapest. 2011.11.28.



Szabó Zoltán László r. alezredes
alosztályvezető



NATO CENTRE OF EXCELLENCE FOR MILITARY MEDICINE
H-1885 Budapest, P.o.B. 25
Phone: +36 (1) 883-0100 • Fax: +36 (1) 883-0120



TO: Dr. Erdőfi-Szabó Attila Ph.D.,
BioLabor Biofizikai- és Laboratóriumi Szolgáltató Kft
H-1122 Budapest Városmajor u. 20. I/20

SUBJECT: **LETTER OF APPRECIATION**

DATE: 18 JUNE 2012

Dear Professor, dear Attila,

Congratulation to your scientific results, which were recently published in Electromagnetic Biology and Medicine (2012.VI, DOI: 10.3109/ 15368378.2012.681823). I see it as a great prospective in future not-yet-conventional training and rehabilitation processes.

With the hope of further successful cooperation I wish you all the best!

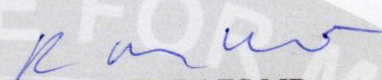
Lieutenant Colonel Robert BALAZS MD
Lessons Learned Branch
Acting Chief